

AZ DISPLAYS

SPECIFICATIONS FOR LIQUID CRYSTAL DISPLAY

CUSTOMER APPROVAL			
※ PART NO. : ATM0499M1A(AZ DISPLAYS) PRELIMINARY			
APPROVAL		COMPANY CHOP	
CUSTOMER COMMENTS			

AZ DISPLAYS ENGINEERING APPROVAL		
DESIGNED BY	CHECKED BY	APPROVED BY
ZZK		

REVISION RECORD

REVISION	REVISION DATE	PAGE	CONTENTS
PRELIMINARY	2022-02-21		FIRST ISSUE
PRELIMINARY	2022-03-21	5	MODIFY FPC

1. Introduction

1.1. Scope of application

This specification applies to the active type TFT transmissive dot matrix LCD module that is supplied by **ZETTLER**. This LCD module should be designed for digital use.

LCD specification: Dots 720xRGBx1280

As to basic specification of the driver IC, refer to the IC (GC9702P) specification and datasheet.

1.2. TFT features

Structure: TFT PANNEL+IC+FPC+BL+TP

Transmissive Type LCD

720 dot-source and 1280 dot-gate outputs

5.0 inch TFT LCD 16.7M Color can be selected by software

White LED back light

MIPI interface

1.3. Applications

PSP

PDA

GPS

Etc...

2. General specification

ITEM	Standard value	UNIT
LCD Type	Transmissive	--
Display Mode	Normally Black	--
Driver element	TFT Active matrix	--
Number of Dots	720×(RGB)×1280	Dots
Pixel Arrangement	RGB Vertical Stripe	--
Active Area	62.10×110.40	mm
Viewing Area (W*H)	/	mm
Viewing Angle(U/D/L/R)	80/80/80/80	deg
Driver IC	GC9702P	--
LCM Size(W*H*T)	66.50×119.60×2.1	mm
Module Size (W*H*T)	/	mm
Approx. Weight	TBD	g
Back Light	White LED	--
Touch Panel Type	/	--
Touch Panel View Area	/	mm
System interface	MIPI	--

3. Mechanical drawing

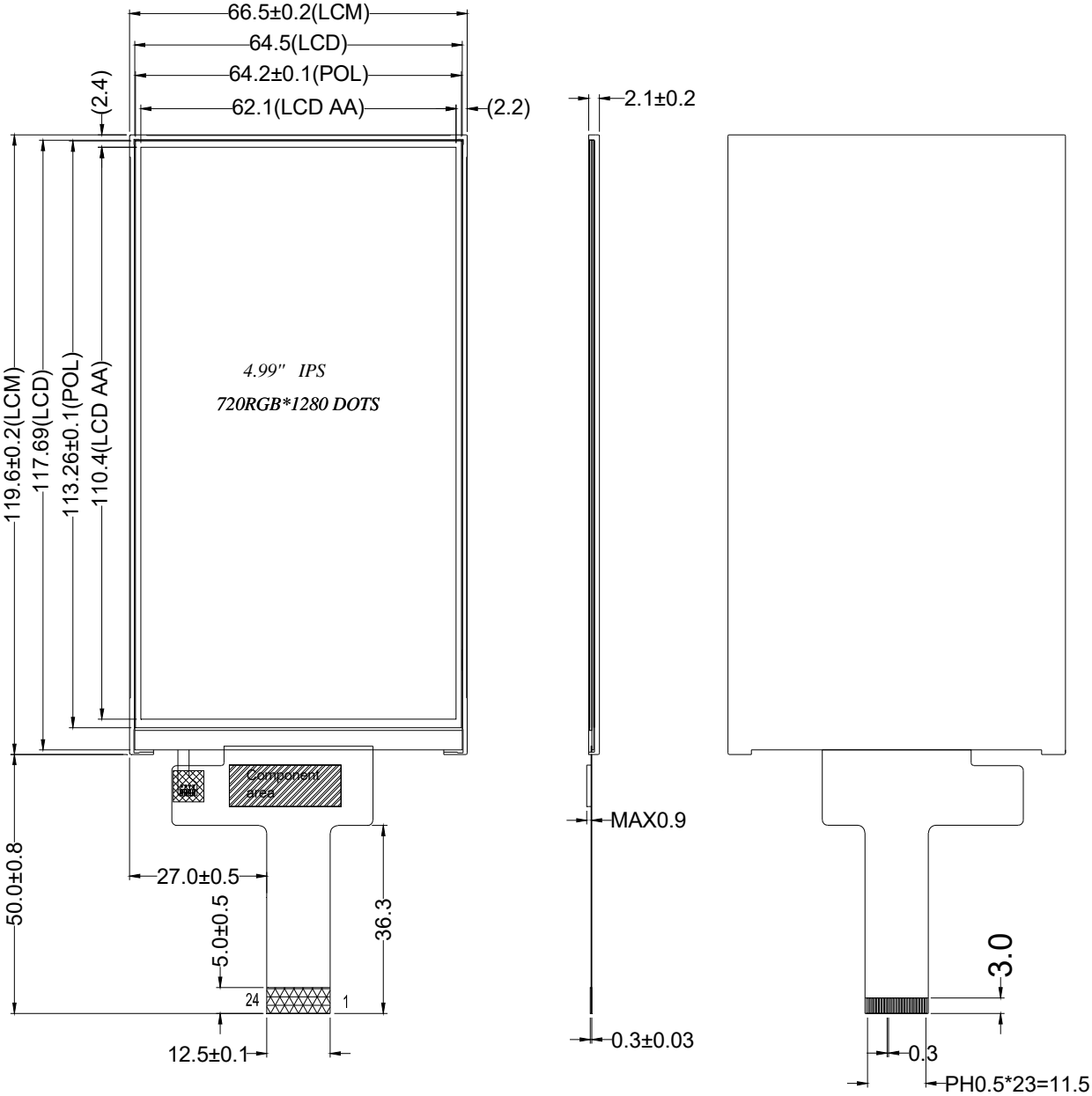

1. Unspecified tolerance: ± 0.3 mm
 2. (.) is for reference

4. ABSOLUTE MAXIMUM RATINGS

Parameter	Symbol	Min	Max	Unit
Interface Supply Voltage	IOVCC	-0.3	+3.6	V
Logic Supply Voltage	VCI	-0.3	+6.6	V
Analog Supply Voltage	VCIP	-0.3	+6.6	V
High speed interface Supply Voltage	VCCH	-0.3	+3.6	V
Positive Voltage input	AVDD	+4.5	+6.0	V
Negative Voltage input	AVEE	-4.5	-6.0	V
Power Supply Voltage	VGH	-0.3	+25.0	V
Power Supply Voltage	VGL	0	-16	V
Supply current (One LED)	I_{LED}	--	20	mA
Operating temperature	T_{OP}	-20	+70	°C
Storage temperature	T_{ST}	-30	+80	°C

5. Electrical characteristics

Item	Symbol	Condition	Min.	Typ.	Max.	Unit
IOVCC	V_{IN}	Interface Supply Voltage	1.65	2.8	3.6	
VCIP	V_{IN}	Logic Supply Voltage	2.5	2.8	6.0	
VCI	V_{IN}	Analog Supply Voltage	2.5	-	6.0	
VCCH	V_{IN}	High speed interface Supply Voltage	1.65	-	3.6	
Input high voltage	V_{IH}	IOVCC= 1.65 ~ 3.3V VCIP= 2.5 ~ 3.3V VCI= 2.5 ~ 3.3V	0.7 IOVCC	-	IOVCC	V
Input low voltage	V_{IL}		0	-	0.3 IOVCC	V
VPP	V_{IH}	VPP	7.25V	7.5V	7.75V	V
	V_{IL}					
Output high voltage (SDO, LEDPWM)	V_{OH1}	$I_{OH} = -1.0$ mA	0.8 IOVCC	-	IOVCC	V
Output low voltage (SDO, LEDPWM)	V_{OL1}	IOVCC= 1.65 ~ 2.4V $I_{OL} = 1.0$ mA	0	-	0.2 IOVCC	V
Logic High level input current	I_{IH}	VSYNC, HSYNC	-	-	1	uA
		RESX, DCX_SCL, CSX, RDX, WRX_SCL	-	-	1	uA
	I_{IHD}	DB[23...0], SDI, DCX DB[23...0]	-	-	1	uA
Logic Low level input current	I_{IL}	VSYNC, HSYNC	-1	-		uA
		RESX, DCX, CSX, RDX, WRX_SCL	-1	-		uA
	I_{ILD}	DB[23...0], SDI, DCX DB[23...0]	-1	-		uA
Current consumption standby mode (VCIP/VCI-VSSD)	$I_{ST(VDD)}$	VCIP/VCI=2.8V, IOVCC=1.8V $T_A = 25^\circ\text{C}$	-	TBD	-	uA
Current consumption standby mode (IOVCC-VSSD)	$I_{ST(IOVCC)}$		-	TBD	-	uA

ATM0499M1A(AZ DISPLAYS)TFT MODULE PRELIMINARY

Current consumption during Deep-standby mode (VCIP/VCII-VSSD)	IDP-ST(VDD)	VCIP/VCII=2.8V, IOVCC=2.8V T _A =25°C	-	TBD	-	uA
Current consumption during Deep-standby mode (IOVCC-VSSD)	IDP-ST(IOVCC)		-	TBD	-	uA

Note: 1. The VOTP pin is open on normal mode and in used while OTP programming condition.
 2. The GRAM data is eliminated under the Deep standby mode.

5.1 LED backlight Power waste Top: Ta=25°C

Number of LED: 12pcs, LED current: 20mA@1pcs

Circuit of LED:

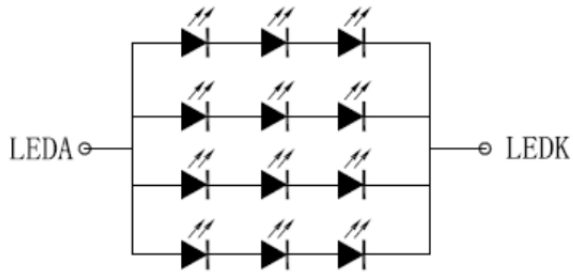

If: =80mA(Vf: =18V typ.)

Parameter	Symbol	Conditions	Min.	Typ.	Max	Unit	Remark
LED forward Current	I _{LED}	--	--	80	--	mA	
LED forward Voltage		I _{LED} =80mA	16.8	18.0	19.8	V	

6. OPTICAL CHARACTERISTICS

ITEM	SYMBOL	CONDITIONS	SPECIFICATIONS			UNIT	NOTE	
			MIN.	TYP.	MAX.			
Brightness	B	Viewing normal angle	550	700	--	Cd/m ²	All left side data are based on HESHENGDA's product reference only	
Contrast Ratio	CR		1000	1200	--	--		
Response Time	Tr+Tf		--	30	35	ms		
CIE Color Coordinate	Red		X _R	--	0.616	--		
			Y _R	--	0.356	--		
	Green		X _G	--	0.331	--		
			Y _G	--	0.599	--		
	Blue		X _B	--	0.155	--		
			Y _B	--	0.088	--		
White	X _w		--	0.29	--			
	Y _w	--	0.31	--				
Viewing Angle	Hor.	θ_{x+}	--	80	--	Deg.		
		θ_{x-}	--	80	--			
	Ver.	θ_{y+}	--	80	--			
		θ_{y-}	--	80	--			
Uniformity	Un		75	--	--	%		

Note 1 : Definition of Viewing Angle θ_x and θ_y :

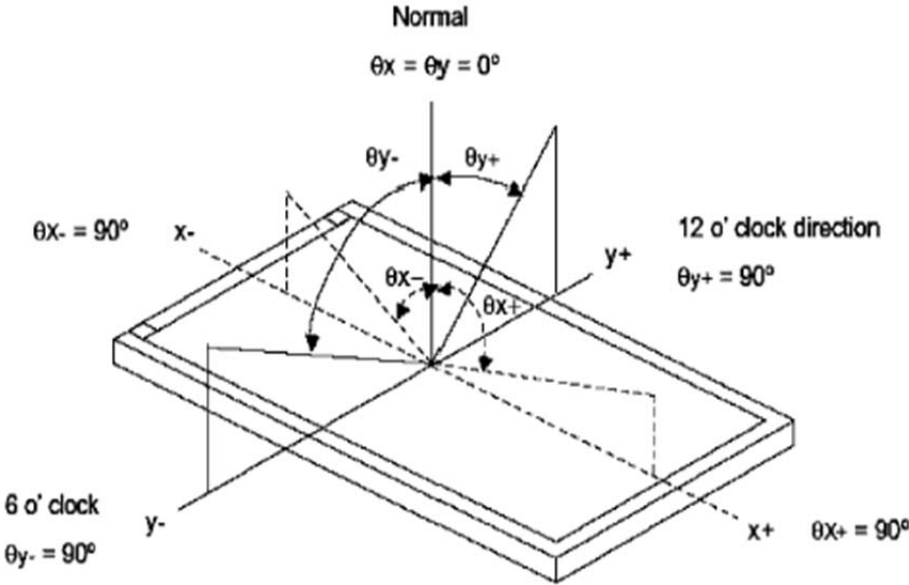

Note 2: Definition of contrast ratio CR:

$$CR = \frac{\text{Brightness of non-selected dots (white)}}{\text{Brightness of selected dots (black)}}$$

Note 3: Definition of response time (T_R , T_F)

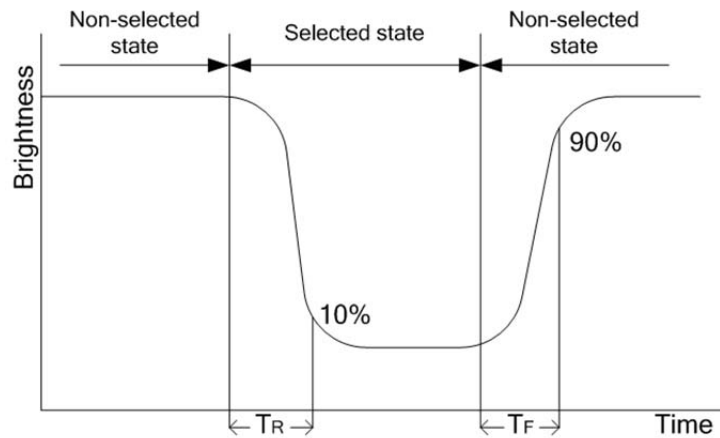

: The brightness test equipment setup
20mA Field=2° (As measuring "black" image, field=2° is the best testing condition)
(One LED)

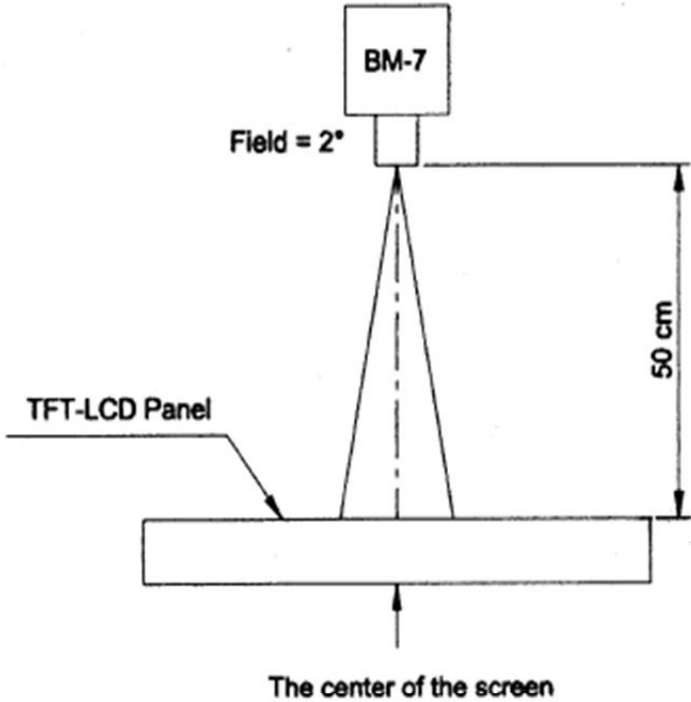

Note 4 :

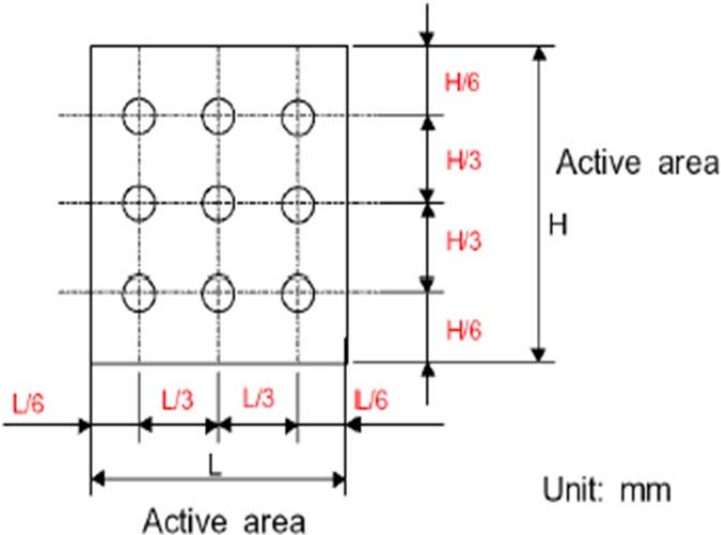

7. Pin Assignment

NO.	SYMBOL	Description
1	GND	Ground
2	GND	Ground
3	D0N	Data0 signals (-)
4	D0P	Data0 signals (+)
5	GND	Ground
6	D1N	Data1 signals (-)
7	D1P	Data1 signals (+)
8	GND	Ground
9	CLKN	Clock signals (-)
10	CLKP	Clock signals (+)
11	GND	Ground
12	D2N	Data2 signals (-)
13	D2P	Data2 signals (+)
14	GND	Ground
15	D3N	Data3 signals (-)
16	D3P	Data3 signals (+)
17	GND	Ground
18	GND	Ground
19	RESET	Chip reset signal
20	LED-K	Back light Cathode
21	LED-A	Back light Anode
22	IOVCC	Power for I/O Ports
23	VCI	Power for system
24	GND	Ground

8. BLOCK DIAGRAM

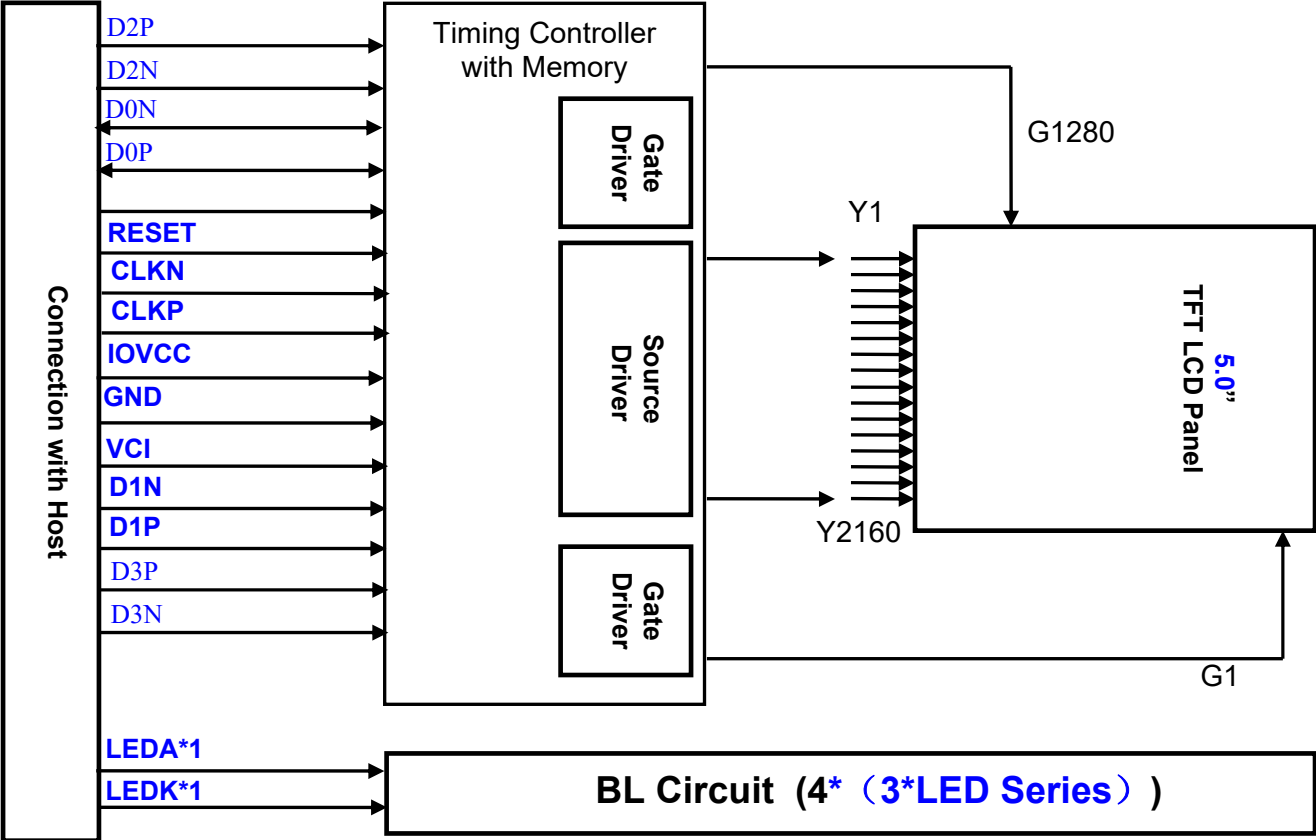

9. LCM Quality Criteria

9.1. VISUAL & FUNCTION INSPECTION STANDARD

9.1.1 Inspection conditions

Inspection performed under the following conditions is recommended.

Temperature: $25 \pm 5^\circ\text{C}$

Humidity: $65\% \pm 10\% \text{RH}$

Viewing Angle: Normal viewing Angle ($90^\circ \pm 45^\circ$);

Illumination: Single fluorescent lamp (800~1200 LUX);

Viewing distance: 25-35cm, time: 5-10s;

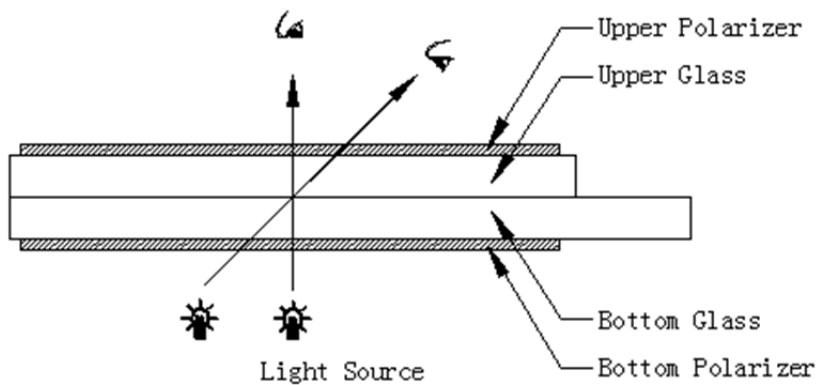

9.1.2 Definition

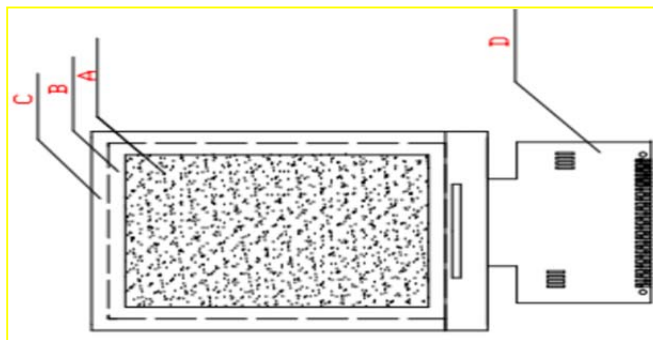

Zone A: LCD AA

Zone B: Viewing Area

Zone C: Outside of the Viewing Area

Note:

As a general rule, visual defects in Zone C can be ignored when it doesn't effect product function or appearance after assembly by customer.

9.1.3 Sampling Plan

According to GB/T 2828-2003;, normal inspection, Class II

AQL:

Major defect	Minor defect
1.0	1.5

LCD: Liquid Crystal Display, TP: Touch Panel, LCM: Liquid Crystal Module

No	Items to be inspected	Criteria	Classification of defects
----	-----------------------	----------	---------------------------

ATM0499M1A(AZ DISPLAYS)TFT MODULE PRELIMINARY

1	Functional defects	1) No display 2) Display abnormally 3) Missing vertical, horizontal segment 4) Short circuit 5) Back-light no lighting, flickering and abnormal lighting 6)Cross-Talk 7)Noise 8)Color contrast	Major
2	Missing	Missing component	
3	Outline dimension	Overall outline dimension beyond the drawing is not allowed	
4	Color tone	Color unevenness, refer to limited sample	Minor
5	Soldering appearance	Good soldering, Peeling off is not allowed.	
6	LCD/Polarizer	Black/White spot/line, scratch, crack, etc.	
7	mura	ND5%, 128 gray	Major
8	Cross-talk	≤ 5%	Minor

9.1.4 Criteria (Visual)

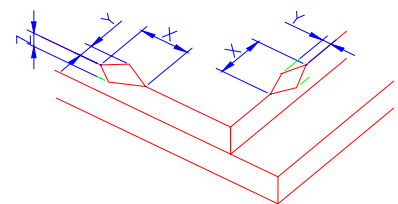
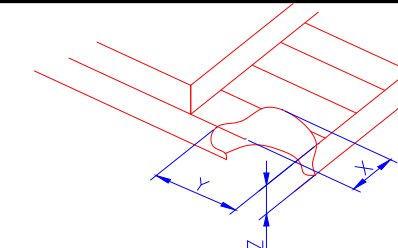
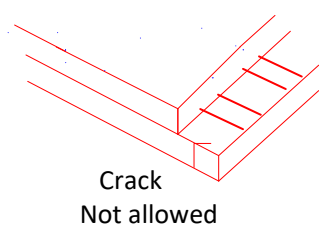
Number	Items	Criteria(mm)						
1.0 LCD Crack/Broken	NOTE: X: Length Y: Width Z: Height L: Length of ITO, T: Height of LCD	 <p>(1) The edge of LCD broken</p> <table border="1" style="margin-left: auto; margin-right: auto;"> <tr> <td style="text-align: center;">X</td> <td style="text-align: center;">Y</td> <td style="text-align: center;">Z</td> </tr> <tr> <td style="text-align: center;">≤1.5mm</td> <td style="text-align: center;"><Inner border line of the seal</td> <td style="text-align: center;">≤T/2</td> </tr> </table>	X	Y	Z	≤1.5mm	<Inner border line of the seal	≤T/2
		X	Y	Z				
		≤1.5mm	<Inner border line of the seal	≤T/2				
 <p>(2) LCD corner broken</p> <table border="1" style="margin-left: auto; margin-right: auto;"> <tr> <td style="text-align: center;">X</td> <td style="text-align: center;">Y</td> <td style="text-align: center;">Z</td> </tr> <tr> <td style="text-align: center;">≤3mm</td> <td style="text-align: center;">≤2mm</td> <td style="text-align: center;">≤T</td> </tr> </table>	X	Y	Z	≤3mm	≤2mm	≤T		
X	Y	Z						
≤3mm	≤2mm	≤T						
 <p>(3) LCD crack</p> <p style="text-align: center;">Crack Not allowed</p>								

Number	Items	Criteria (mm)
--------	-------	---------------

ATM0499M1A(AZ DISPLAYS)TFT MODULE **PRELIMINARY**

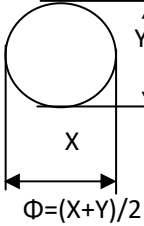
2.0	Spot defect	① light dot (LCD/TP/Polarizer black/white spot , light dot, pinhole, dent, stain)																									
		<table border="1"> <thead> <tr> <th rowspan="2">Zone Size (mm)</th> <th colspan="3">Acceptable Qty</th> </tr> <tr> <th>A</th> <th>B</th> <th>C</th> </tr> </thead> <tbody> <tr> <td>$\Phi \leq 0.15$</td> <td colspan="3">Ignore</td> </tr> <tr> <td>$0.15 < \Phi \leq 0.2$</td> <td colspan="3">3</td> </tr> <tr> <td>$0.2 < \Phi \leq 0.3$</td> <td colspan="3">2</td> </tr> <tr> <td>$0.3 < \Phi$</td> <td colspan="3">0</td> </tr> </tbody> </table>	Zone Size (mm)	Acceptable Qty			A	B	C	$\Phi \leq 0.15$	Ignore			$0.15 < \Phi \leq 0.2$	3			$0.2 < \Phi \leq 0.3$	2			$0.3 < \Phi$	0			Ignore	
Zone Size (mm)		Acceptable Qty																									
	A	B	C																								
$\Phi \leq 0.15$	Ignore																										
$0.15 < \Phi \leq 0.2$	3																										
$0.2 < \Phi \leq 0.3$	2																										
$0.3 < \Phi$	0																										
		② Dim spot (LCD/TP/Polarizer dim dot, light leakage、dark spot)																									
		<table border="1"> <thead> <tr> <th rowspan="2">Zone Size (mm)</th> <th colspan="3">Acceptable Qty</th> </tr> <tr> <th>A</th> <th>B</th> <th>C</th> </tr> </thead> <tbody> <tr> <td>$\Phi \leq 0.15$</td> <td colspan="3">Ignore</td> </tr> <tr> <td>$0.15 < \Phi \leq 0.2$</td> <td colspan="3">3(D>10mm)</td> </tr> <tr> <td>$0.2 < \Phi \leq 0.3$</td> <td colspan="3">2</td> </tr> <tr> <td>$\Phi > 0.3$</td> <td colspan="3">0</td> </tr> </tbody> </table>	Zone Size (mm)	Acceptable Qty			A	B	C	$\Phi \leq 0.15$	Ignore			$0.15 < \Phi \leq 0.2$	3(D>10mm)			$0.2 < \Phi \leq 0.3$	2			$\Phi > 0.3$	0			Ignore	
Zone Size (mm)	Acceptable Qty																										
	A	B	C																								
$\Phi \leq 0.15$	Ignore																										
$0.15 < \Phi \leq 0.2$	3(D>10mm)																										
$0.2 < \Phi \leq 0.3$	2																										
$\Phi > 0.3$	0																										
	Line defect (LCD /Polarizer black/white line, scratch, stain)	<table border="1"> <thead> <tr> <th>Width(mm)</th> <th>Length(mm)</th> <th>Acceptable Qty</th> </tr> </thead> <tbody> <tr> <td>$\Phi \leq 0.05$</td> <td>Ignore</td> <td>Ignore</td> </tr> <tr> <td>$0.05 < W \leq 0.1$</td> <td>$L \leq 5$</td> <td>2</td> </tr> <tr> <td>$0.1 < W$</td> <td colspan="2">$W > 0.1$ for Spot defect</td> </tr> </tbody> </table>	Width(mm)	Length(mm)	Acceptable Qty	$\Phi \leq 0.05$	Ignore	Ignore	$0.05 < W \leq 0.1$	$L \leq 5$	2	$0.1 < W$	$W > 0.1$ for Spot defect														
Width(mm)	Length(mm)	Acceptable Qty																									
$\Phi \leq 0.05$	Ignore	Ignore																									
$0.05 < W \leq 0.1$	$L \leq 5$	2																									
$0.1 < W$	$W > 0.1$ for Spot defect																										
3.0	Polarizer scratch	<table border="1"> <thead> <tr> <th>Width(mm)</th> <th>Length(mm)</th> <th>Acceptable Qty</th> </tr> </thead> <tbody> <tr> <td>$W \leq 0.05$</td> <td>Ignore</td> <td>Ignore</td> </tr> <tr> <td>$0.05 < W \leq 0.1$</td> <td>$L \leq 5$</td> <td>2</td> </tr> <tr> <td>$0.05 < W$</td> <td colspan="2">$W > 0.1$ for Spot defect</td> </tr> </tbody> </table>	Width(mm)	Length(mm)	Acceptable Qty	$W \leq 0.05$	Ignore	Ignore	$0.05 < W \leq 0.1$	$L \leq 5$	2	$0.05 < W$	$W > 0.1$ for Spot defect														
	Width(mm)	Length(mm)	Acceptable Qty																								
$W \leq 0.05$	Ignore	Ignore																									
$0.05 < W \leq 0.1$	$L \leq 5$	2																									
$0.05 < W$	$W > 0.1$ for Spot defect																										
	Polarizer Bubble	<table border="1"> <thead> <tr> <th>Zone Size (mm)</th> <th>Acceptable Qty</th> </tr> </thead> <tbody> <tr> <td>$\Phi \leq 0.2$</td> <td>Ignore</td> </tr> <tr> <td>$0.2 < \Phi \leq 0.4$</td> <td>3</td> </tr> <tr> <td>$0.4 < \Phi$</td> <td>0</td> </tr> </tbody> </table>	Zone Size (mm)	Acceptable Qty	$\Phi \leq 0.2$	Ignore	$0.2 < \Phi \leq 0.4$	3	$0.4 < \Phi$	0																	
Zone Size (mm)	Acceptable Qty																										
$\Phi \leq 0.2$	Ignore																										
$0.2 < \Phi \leq 0.4$	3																										
$0.4 < \Phi$	0																										
4.0	SMT	According to the <Acceptability of electronic assemblies> IPC-A-610C class 2 standard. Component missing or function defect are Major defect, the others are Minor defect.																									

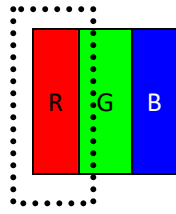
5.0	TFT	distinguish	type	Acceptable Qty	 <p style="text-align: center;">Dot</p>
		Bright dot	Any color window	Judge according to 2.0 in 9.1.4	
			Adjacent Bright dot		
		Dark dot	Dark dot		
Adjacent Dark dot					
Note: the red (R), green, blue (G), (B) 3 points constitute a pixel					

9.2. RELIABILITY TEST

ITEM	Condition	Sample size	Criterion
High Temp. Storage	80°C, 48 hrs	5pcs	Inspection after 2~4hours storage at room temperature, the sample shall be free from defects: 1.Air bubble in the LCD; 2.Sealleak; 3.Non-display; 4.Missing segments; 5. The surface shall be free from damage. 6. Contrast must be no more than 10% by the linearity tester. 7. Power must be no more than 10% by the linearity tester.
Low Temp. Storage	-30°C, 48 hrs	5pcs	
High Temp. Operation	70°C, 48 hrs	5pcs	
Low Temp. Operation	-20°C, 48 hrs	5pcs	
Humidity operation	40°C, 90%RH, 48 hrs	5pcs	
Humidity storage	60°C, 90%RH, 48 hrs	5pcs	
Thermal shock	-30°C/30min → 70°C/30mins Total:16cycles	5pcs	
Simulated transport	Reciprocating, 190+/-10 Ring, 2 hours, amplitude 25.4MM	1Carton-box	After testing, there are no any defective appearances or electrical properties.
Packaging drop	Six faces, Three edge (Diagonal landing), The weight and height correspond to the following 0 to 45.4KG: 80CM; 45.4-90.8KG: 60CM; 90.8-454KG: 45CM; OVER454KG: 40CM	1Carton-box	
ESD	1.Contact discharge method±4KV, 150pF/330Ω 10times (Can not face the role of IC)	5pcs	1. After testing, there are no any defective appearances or electrical properties 2. It can be acceptable when all defective ESD disappears in the RESET 3. This test is for the assembled product
	2.Air discharge method±4KV,150pF/330Ω 10times (Can not face the role of IC)	5pcs	

9.3. Safety instructions

9.3.1 If the LCD panel breaks, be careful not to get any liquid crystal substance in your mouth.

9.3.2 If the liquid crystal substance touches your skin or clothes, please wash it off immediately by using soap and water.

9.4. Handling Precautions

9.4.1 Avoid static electricity damaging the LSI.

9.4.2 Do not remove the panel or frame from the module.

9.4.3 The polarizing plate of the display is very fragile. So, please handle it very carefully.

9.4.4 Do not wipe the polarizing plate with a dry cloth, as it may easily scratch the surface of the plate.

9.4.5 The color tone of display and background of LCM has the possibility to be changed in the storage temperature range.

9.4.6 Pay attention to the working environment, as the element may be destroyed by static electricity.

--Be sure to ground human body and electric appliance during work.

--Avoid working in a dry environment to minimize the generations of static electricity.

--Static electricity may be generated when the protective film is fast peeled off.

9.4.7 When soldering the terminal of LCM, make certain the AC power source of soldering iron does not leak.

9.4.8 If the display surface becomes contaminated, breathe on the surface and gently wipe it with a soft-dry-clean cloth. If it is heavily contaminated, moisten cloth with the following solvent (ex: Ethyl alcohol). Solvents other than those above-mentioned may damage the polarizer (Especially, do not use them. ex: Warter / Ketone)

9.5. Operation instructions

9.5.1 It is recommended to drive the LCD within the specified voltage limits, try to adjust the operating voltage for the optimal contrast, the color and contrast of LCD panel will varies at different temperature.

9.5.2 Response time is greatly delayed at low operating temperature range. However, this does not mean the LCD will be out of the order, It will recover when it returns to the specified temperature range.

9.5.3 If the display area is pushed hard during operation, the display will become abnormal.

9.5.4 Do not operate the LCD at the environments over the specified conditions, this may cause damage on the LCD and shorten the lifetime.

9.6. Storage instructions:

9.6.1 Store LCDs in a sealed polyethylene bag.

9.6.2 Store LCDs in a dark place, Do not expose to sunlight or fluorescent light. Keep the temperature between 20°C and 30°C.

9.6.3 Avoid the polarizer touch any other object, (It is recommended to store them in the container in which they were shipped.)

9.7. Limited Warranty

9.7.1 will replace or repair any of its LCD modules, which are found to be defective, when inspected in accordance with LCM acceptance standards (copies available upon request) for a period of 12 months from ink- print date on product

9.7.2 Any defects must be returned to within 60 days since ship-out. Confirmation of such date shall be based on freight documents. The warranty liability of wasam limited to repair and/or replacement on defects above (7.1,7.2)

9.7.3 No warranty can be granted if the precautions stated above have been disregarded. The typical samples are as below:

-- LCD glass crack/break

--PCB outlet is damaged or modified.

--PCB conductors damaged.

--Circuit modified with by grinding, engraving or painting varnish.

--FPC crack

9.7.4 Modules must be returned with sufficient description of the failures of defects. Any connectors or cable installed by the customer must be removed completely without damaging the PCB outlet, conductors and terminals. Modules must be packed with the container in which they were shipped.

9.8 Determination of surface smudges and dust spots:

9.8.1 The dirt and dust points that cannot be wiped shall be judged by the dot line standard. The dirt and dust points that can be wiped shall be regarded as good products

10. Packing method

T.B.D