

AZ DISPLAYS

SPECIFICATIONS FOR LIQUID CRYSTAL DISPLAY

CUSTOMER APPROVAL			
※ PART NO. :ATM0154B1 (AZ DISPLAYS) SPEC VER1.4			
APPROVAL		COMPANY CHOP	
CUSTOMER COMMENTS			

AZ DISPLAYS ENGINEERING APPROVAL		
DESIGNED BY	CHECKED BY	APPROVED BY
ZHENGZK	LIJF	GZH

Records of Revision

DATE	REF.PAGE PARAGRAPH DRAWING No.	REVISED No.	SUMMARY	REMARK
2019-02-28	ALL	1.0	FIRST ISSUE	
2019-06-28	6	1.1	ADD LIFETIME PARAMETER	
2019-07-03	8	1.2	ADD BRIGHTNESS INFORMATION	
2019-07-10	5,6	1.3	UPDATE PARAMETERS	
2019-08-29	4	1.4	CHANGE SPEC FORMAT	

Contents

1	Introduction-----	4
2	General specification-----	4
3	Mechanical drawing-----	5
4	Absolute maximum ratings-----	6
5	Electrical characteristics-----	6
6	Optical characteristics -----	7
7	Pin Assignment -----	10
8	Block diagram -----	11
9	LCM quality criteria-----	12
10	Packing method-----	17

1. Introduction

Scope of application

This specification applies to the Negative type TFT transmissive dot matrix LCD module. This LCD module should be designed for consumer products application which does not work under stringent environment.

2. General specification

Item	Specification	Remark
1. LCD size	1.54 inch(Diagonal)	
2. Driver element	a-Si TFT active matrix	
3. Resolution	240x(RGB)x240	
4. Display mode	Normally Black, IPS, Transmissive	
5. Dot Pitch (W*H)	0.0385mm(W) x 0.1155mm(H)	
6. Pixel pitch(W*H)	0.1155mm(W) x 0.1155mm(H)	
7. Active Area(W*H)	27.72mm(W) x 27.72mm(H)	
8. Module size (W*H)	31.52mm(W) x 33.72(H) x1.95mm(D)	Note 1
9. Surface treatment	Anti-glare	
10. Color arrangement	RGB-stripe	
11. Color	262K	
12. Viewing angle (L/R/T/B)	80/80/80/80	
13. Interface	4-W SPI interface	
14. LCD controller	ST7789V2	
15. LCM Brightness	500 cd/m2 Typ.	
16. Backlight driving condition	20mA @9.0V	
17. Touch panel	N.A.	
18. Touch controller	N.A.	
19. Operation Temperature	-20~60 °C	
20. Weight	3.2g Typ.	
21. RoHS	RoHS compliant	

Note 1: Please refer to mechanical drawing.

3. Mechanical drawing

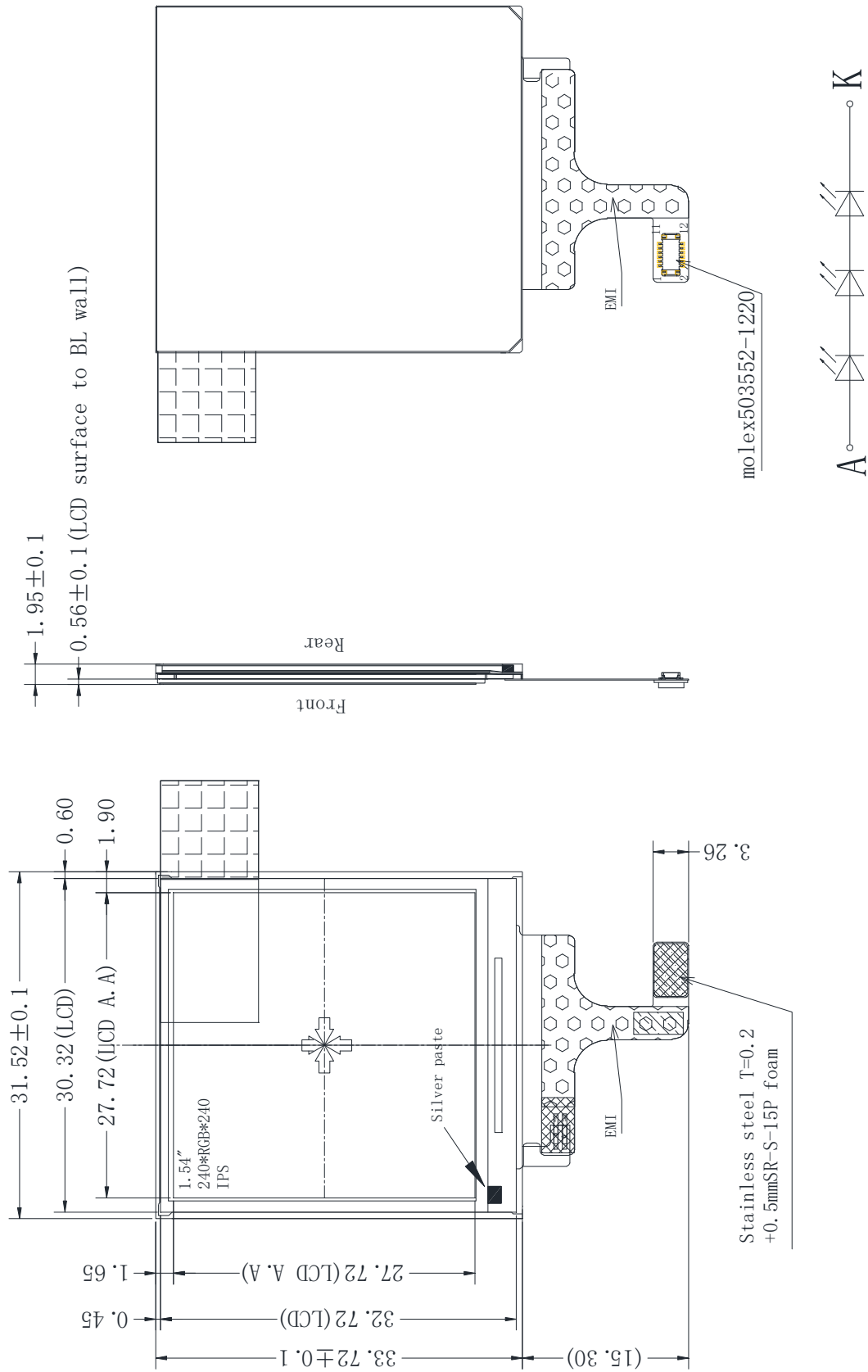

$I_f=20\text{mA}$ $V_f=8.4 \sim 10.5\text{V}$

Note: Unspecified tolerance $\pm 0.2\text{mm}$

4. ABSOLUTE MAXIMUM RATINGS

Parameter	Symbol	Min	Max	Unit
Power Supply LCD voltage 1	IOVCC-VSS	-0.3	+4.6	V
Power Supply LCD voltage 2	VCI-VSS	-0.3	+4.6	V
Power Supply LCD voltage 3	VGH-VGL	-0.3	+30.0	V
Power Supply TP voltage 1	IOVCC-VSS	/	/	V
Power Supply TP voltage 2	VDD-VSS	/	/	V
Supply current (One LED)	I_{LED}	--	20	mA
Operating temperature	T_{OP}	-20	+60	°C
Storage temperature	T_{ST}	-30	+70	°C

5. Electrical characteristics

Item	Symbol	Min	Typ	Max	Unit	Applicable terminal
Power Supply voltage for LCD	IOVCC	+1.65	+1.8	+3.3	V	
	VCI	+2.4	+2.75	+3.3	V	
	VGH	+12.2	/	+14.97	V	
	VGL	-12.5	/	-7.16	V	
Power Supply voltage for TP	TPVDD	/	/	/	V	
Logic Low level Input voltage	V_{IL}	VSS	--	0.3IOVCC	V	
Logic High level Input voltage	V_{IH}	0.7IOVCC	--	IOVCC	V	
Logic Low level output voltage	V_{oL}	VSS	--	0.2IOVCC	V	
Logic High level output voltage	V_{oH}	0.8IOVCC	--	IOVCC	V	
Input leakage current	I_{LKG}	5		50	μA	
LED Forward voltage	V_f	--	9	--	V	
Input backlight current	I_{LED}	--	20	--	mA	1* (3*LED Series)

5.1 LED backlight Power waste Top: Ta=25°C

Number of LED: 3pcs, LED current: 20mA@1pcs

Circuit of LED:

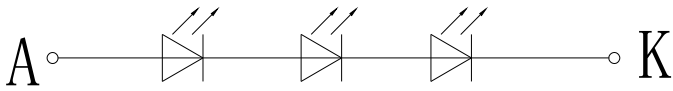

$$I_f = 20\text{mA} \quad V_f = 8.4 \sim 10.5\text{V}$$

Parameter	Symbol	Conditions	Min.	Typ.	Max	Unit	Remark
LED forward Current	I _{LED}	--	--	20	--	mA	@1lane
LED forward Voltage		I _{LED} =20mA	--	9.0	--	V	@1lane
Power Consumption		I _{LED} =20mA	--	180	--	mW	@1lane
Life time		I _{LED} =20mA	--	50K	--	Hours	

6. OPTICAL CHARACTERISTICS

ITEM	SYMBOL	CONDITIONS	SPECIFICATIONS			UNIT	NOTE	
			MIN.	TYP.	MAX			
Brightness	B	Viewing normal angle	400	500	--	cd/m ²	--	
Contrast Ratio	CR		700	900	--	--		
Response Time	Tr+Tf		--	30	35	ms		
CIE Color coordinate	Red		X _R	--	0.631	--		
			Y _R	--	0.330	--		
	Green		X _G	--	0.282	--		
			Y _G	--	0.544	--		
	Blue		X _B	--	0.138	--		
			Y _B	--	0.155	--		
White	X _w		--	0.29	--			
	Y _w	--	0.31	--				
Viewing Angle	Hor.	θ_{x+}	70	80	--	Deg.		
		θ_{x-}	70	80	--			
	Ver.	θ_{y+}	70	80	--			
		θ_{y-}	70	80	--			
NTSC			--	50%		CIE1931		
Uniformity	Un		80	--	--	%		

Note 1 : Definition of Viewing Angle θ_x and θ_y :

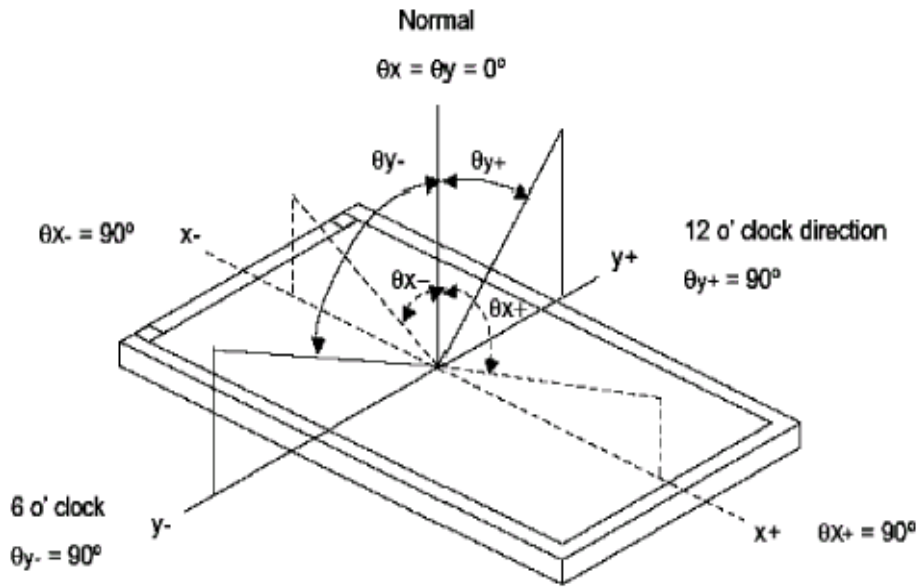

Note 2: Definition of contrast ratio CR:

$$CR = \frac{\text{Brightness of non-selected dots (white)}}{\text{Brightness of selected dots (black)}}$$

Note 3: Definition of response time (T_R , T_F)

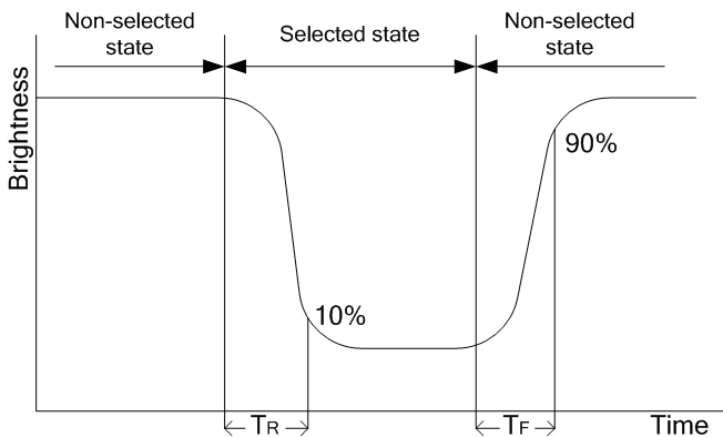

: The brightness test equipment setup
 20mA Field=2° (As measuring "black" image, field=2° is the best testing condition)
 (One LED)

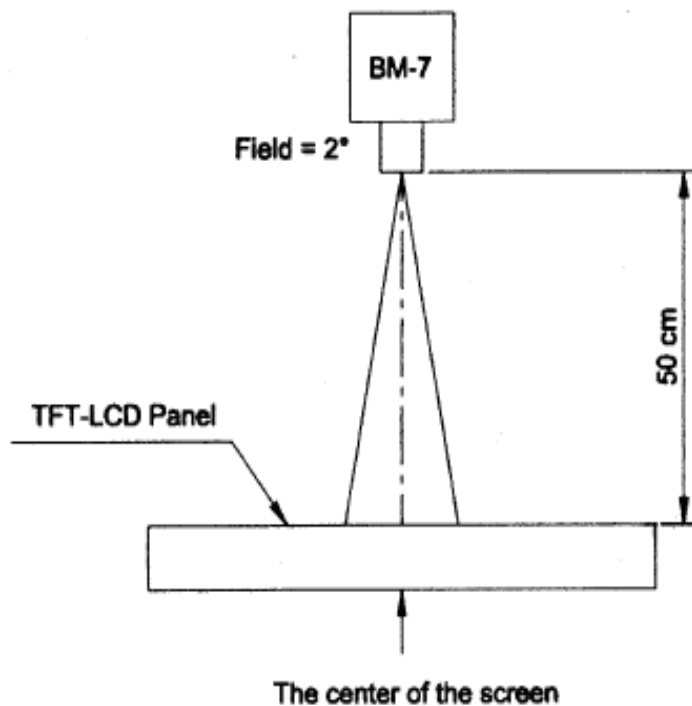

Note 4 :

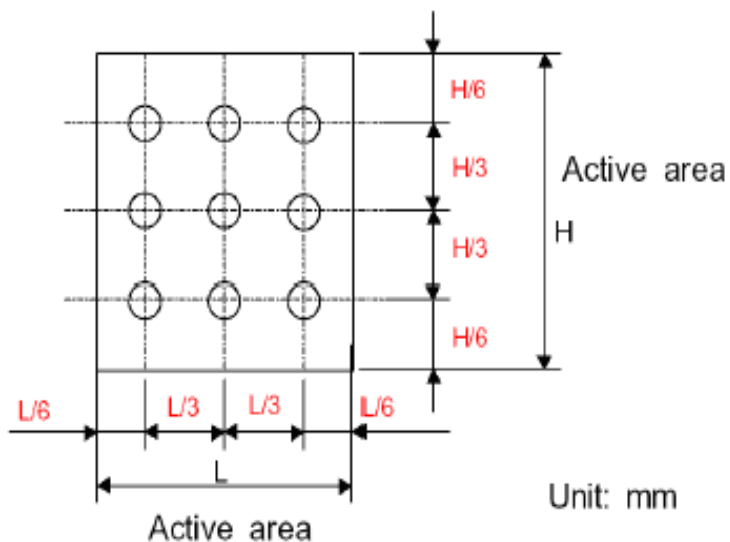

7. Pin Assignment

NO.	SYMBOL	Description
1	SDA	Serial data input/output
2	VDD3V0	Power supply
3	RS	Data /Command selection pin
4	IOVDD1V8	Power supply
5	GND	Ground
6	FMARK	Tearing effect input
7	CLK	Serial clock
8	RESET	Chip reset signa
9	CS	Data /Command selection pin
10	LED+	Back light anode
11	GND	Ground
12	LED-	Back light Cathode

8. BLOCK DIAGRAM

Driver IC: ST7789V2-G4-A or Compatible

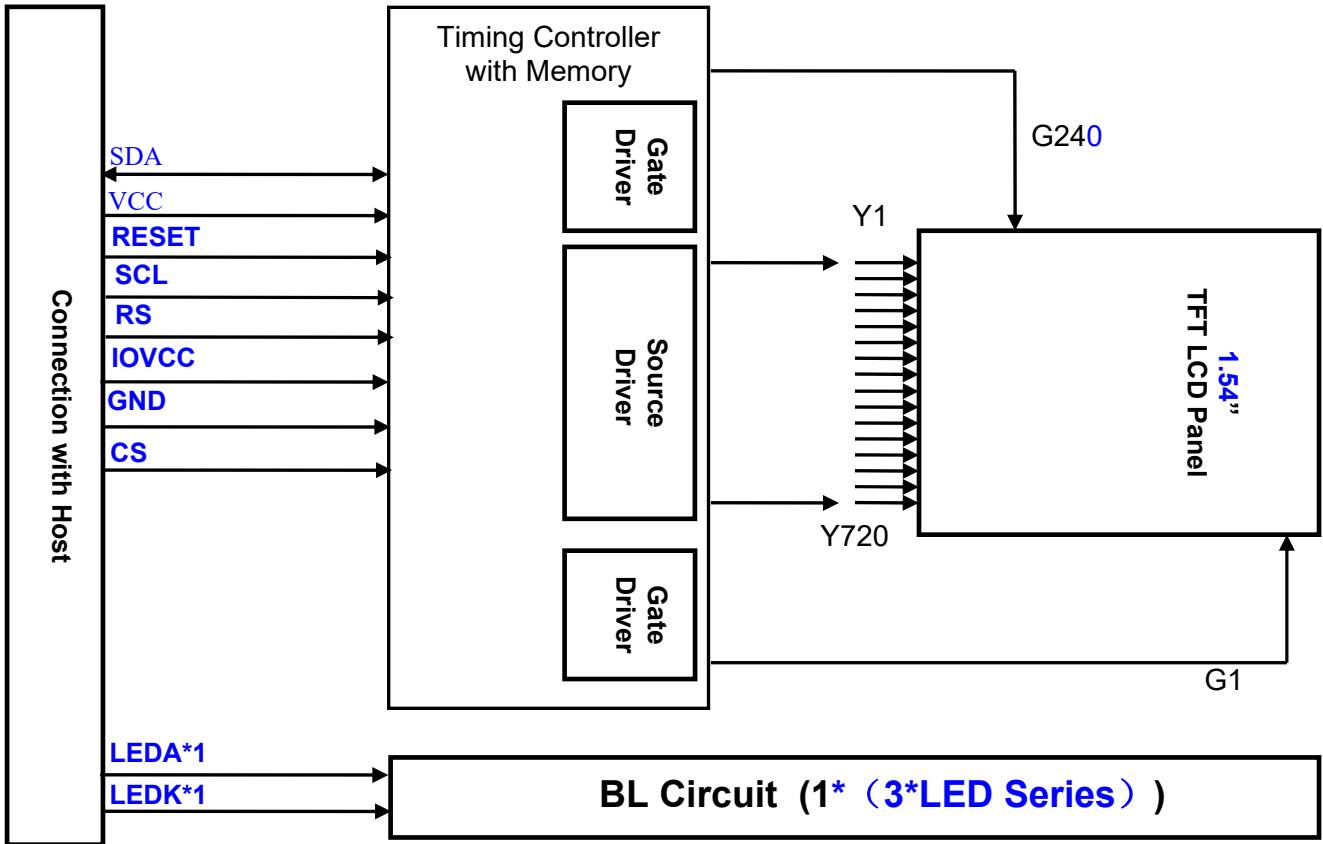

9. LCM Quality Criteria

9.1. VISUAL & FUNCTION INSPECTION STANDARD

9.1.1 Inspection conditions

Inspection performed under the following conditions is recommended.

Temperature: 25±5°C

Humidity: 65%±10%RH

Viewing Angle: Normal viewing Angle (90°±45°);

Illumination: Single fluorescent lamp (800~1200 LUX) ;

Viewing distance: 25-35cm, time: 5-10s;

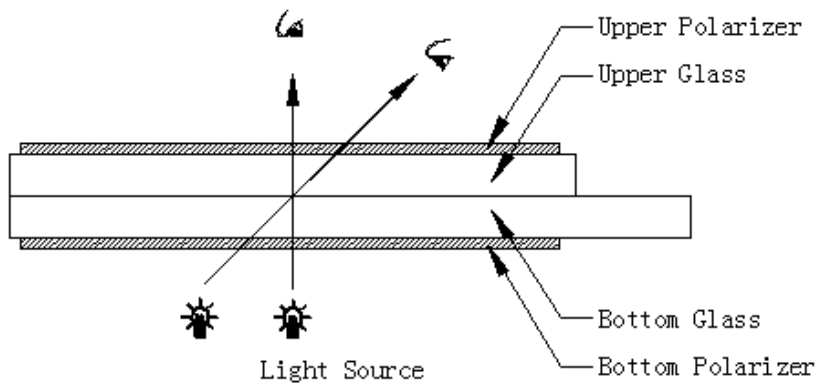

9.1.2 Definition

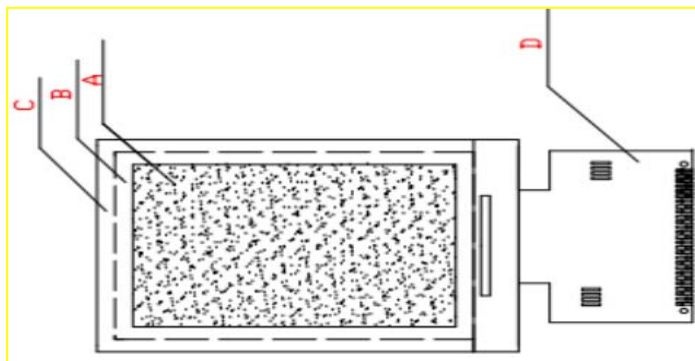

Zone A: LCD AA

Zone B: Viewing Area

Zone C: Outside of the Viewing Area

Note:

As a general rule, visual defects in Zone C can be ignored when it doesn't effect product function or appearance after assembly by customer.

9.1.3 Sampling Plan

According to GB/T 2828-2003; , normal inspection, Class II

AQL:

Major defect	Minor defect
0.65	1.5

LCD: Liquid Crystal Display, TP: Touch Panel, LCM: Liquid Crystal Module

No	Items to be inspected	Criteria	Classification of defects
1	Functional defects	1) No display 2) Display abnormally 3) Missing vertical, horizontal segment 4) Short circuit 5) Back-light no lighting, flickering and abnormal lighting 6)Cross-Talk 7)Noise 8)Color contrast	Major
2	Missing	Missing component	Major
3	Outline dimension	Overall outline dimension beyond the drawing is not allowed	
4	Color tone	Color unevenness, refer to limited sample	
5	Soldering appearance	Good soldering, Peeling off is not allowed.	Minor
6	LCD/Polarizer	Black/White spot/line, scratch, crack, etc.	
7	mura	ND5%, 128 gray	Major
8	Cross-talk	≤ 5%	Minor

9.1.4 Criteria (Visual)

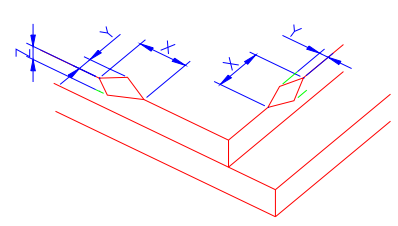
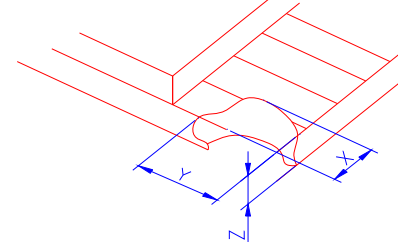
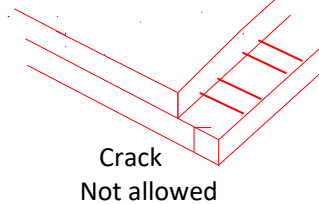
Number	Items	Criteria(mm)						
1.0 LCD Crack/Broken	NOTE: X: Length Y: Width Z: Height L: Length of ITO, T: Height of LCD	 <p>(1) The edge of LCD broken</p> <table border="1" data-bbox="845 1176 1388 1332"> <thead> <tr> <th>X</th> <th>Y</th> <th>Z</th> </tr> </thead> <tbody> <tr> <td>≤1.5mm</td> <td><Inner border line of the seal</td> <td>≤T/2</td> </tr> </tbody> </table>	X	Y	Z	≤1.5mm	<Inner border line of the seal	≤T/2
		X	Y	Z				
		≤1.5mm	<Inner border line of the seal	≤T/2				
 <p>(2)LCD corner broken</p> <table border="1" data-bbox="901 1624 1332 1691"> <thead> <tr> <th>X</th> <th>Y</th> <th>Z</th> </tr> </thead> <tbody> <tr> <td>≤3mm</td> <td>≤2mm</td> <td>≤T</td> </tr> </tbody> </table>	X	Y	Z	≤3mm	≤2mm	≤T		
X	Y	Z						
≤3mm	≤2mm	≤T						
 <p>(3) LCD crack</p> <p>Crack Not allowed</p>								

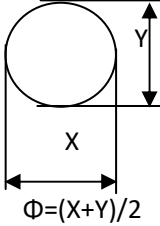
Number	Items	Criteria (mm)																																																										
2.0	Spot defect 	<p>① light dot (LCD/TP/Polarizer black/white spot, light dot, pinhole, dent, stain)</p> <table border="1" data-bbox="464 264 1251 629"> <thead> <tr> <th rowspan="2">Zone Size (mm)</th> <th colspan="3">Acceptable Qty</th> </tr> <tr> <th>A</th> <th>B</th> <th>C</th> </tr> </thead> <tbody> <tr> <td>$\Phi \leq 0.10$</td> <td colspan="3">Ignore</td> </tr> <tr> <td>$0.10 < \Phi \leq 0.15$</td> <td colspan="3">2</td> </tr> <tr> <td>$0.15 < \Phi \leq 0.2$</td> <td colspan="3">1</td> </tr> <tr> <td>$0.2 < \Phi$</td> <td colspan="3">0</td> </tr> </tbody> </table> <p>② Dim spot (LCD/TP/Polarizer dim dot, light leakage, dark spot)</p> <table border="1" data-bbox="464 696 1251 1061"> <thead> <tr> <th rowspan="2">Zone Size (mm)</th> <th colspan="3">Acceptable Qty</th> </tr> <tr> <th>A</th> <th>B</th> <th>C</th> </tr> </thead> <tbody> <tr> <td>$\Phi \leq 0.1$</td> <td colspan="3">Ignore</td> </tr> <tr> <td>$0.1 < \Phi \leq 0.2$</td> <td colspan="3">2(D>10mm)</td> </tr> <tr> <td>$0.2 < \Phi \leq 0.3$</td> <td colspan="3">1</td> </tr> <tr> <td>$\Phi > 0.3$</td> <td colspan="3">0</td> </tr> </tbody> </table> <p>Line defect (LCD /Polarizer black/white line, scratch, stain)</p> <table border="1" data-bbox="464 1099 1273 1406"> <thead> <tr> <th>Width(mm)</th> <th>Length(mm)</th> <th>Acceptable Qty</th> </tr> </thead> <tbody> <tr> <td>$\Phi \leq 0.03$</td> <td>Ignore</td> <td>Ignore</td> </tr> <tr> <td>$0.03 < W \leq 0.05$</td> <td>$L \leq 1.5$</td> <td>1</td> </tr> <tr> <td>$0.05 < W$</td> <td colspan="2">$W > 0.05$ for Spot defect</td> </tr> </tbody> </table>	Zone Size (mm)	Acceptable Qty			A	B	C	$\Phi \leq 0.10$	Ignore			$0.10 < \Phi \leq 0.15$	2			$0.15 < \Phi \leq 0.2$	1			$0.2 < \Phi$	0			Zone Size (mm)	Acceptable Qty			A	B	C	$\Phi \leq 0.1$	Ignore			$0.1 < \Phi \leq 0.2$	2(D>10mm)			$0.2 < \Phi \leq 0.3$	1			$\Phi > 0.3$	0			Width(mm)	Length(mm)	Acceptable Qty	$\Phi \leq 0.03$	Ignore	Ignore	$0.03 < W \leq 0.05$	$L \leq 1.5$	1	$0.05 < W$	$W > 0.05$ for Spot defect	
Zone Size (mm)	Acceptable Qty																																																											
	A	B	C																																																									
$\Phi \leq 0.10$	Ignore																																																											
$0.10 < \Phi \leq 0.15$	2																																																											
$0.15 < \Phi \leq 0.2$	1																																																											
$0.2 < \Phi$	0																																																											
Zone Size (mm)	Acceptable Qty																																																											
	A	B	C																																																									
$\Phi \leq 0.1$	Ignore																																																											
$0.1 < \Phi \leq 0.2$	2(D>10mm)																																																											
$0.2 < \Phi \leq 0.3$	1																																																											
$\Phi > 0.3$	0																																																											
Width(mm)	Length(mm)	Acceptable Qty																																																										
$\Phi \leq 0.03$	Ignore	Ignore																																																										
$0.03 < W \leq 0.05$	$L \leq 1.5$	1																																																										
$0.05 < W$	$W > 0.05$ for Spot defect																																																											
3.0	Polarizer scratch	<table border="1" data-bbox="464 1529 1254 1720"> <thead> <tr> <th>Width(mm)</th> <th>Length(mm)</th> <th>Acceptable Qty</th> </tr> </thead> <tbody> <tr> <td>$W \leq 0.03$</td> <td>Ignore</td> <td>Ignore</td> </tr> <tr> <td>$0.03 < W \leq 0.05$</td> <td>$L \leq 5$</td> <td>1</td> </tr> <tr> <td>$0.05 < W$</td> <td>0</td> <td>0</td> </tr> </tbody> </table>	Width(mm)	Length(mm)	Acceptable Qty	$W \leq 0.03$	Ignore	Ignore	$0.03 < W \leq 0.05$	$L \leq 5$	1	$0.05 < W$	0	0																																														
Width(mm)	Length(mm)	Acceptable Qty																																																										
$W \leq 0.03$	Ignore	Ignore																																																										
$0.03 < W \leq 0.05$	$L \leq 5$	1																																																										
$0.05 < W$	0	0																																																										

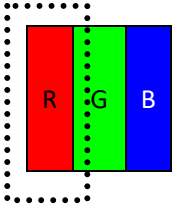
	Polarizer Bubble	<table border="1"> <tr> <th>Zone Size (mm)</th> <th>Acceptable Qty</th> </tr> <tr> <td>$\Phi \leq 0.1$</td> <td>Ignore</td> </tr> <tr> <td>$0.1 < \Phi \leq 0.2$</td> <td>2 (D\geq15mm)</td> </tr> <tr> <td>$0.2 < \Phi$</td> <td>0</td> </tr> </table>	Zone Size (mm)	Acceptable Qty	$\Phi \leq 0.1$	Ignore	$0.1 < \Phi \leq 0.2$	2 (D \geq 15mm)	$0.2 < \Phi$	0						
Zone Size (mm)	Acceptable Qty															
$\Phi \leq 0.1$	Ignore															
$0.1 < \Phi \leq 0.2$	2 (D \geq 15mm)															
$0.2 < \Phi$	0															
4.0	SMT	According to the <Acceptability of electronic assemblies> IPC-A-610C class 2 standard. Component missing or function defect are Major defect, the others are Minor defect.														
5.0	TFT	<table border="1"> <thead> <tr> <th>distinguish</th> <th>type</th> <th>Acceptable Qty</th> </tr> </thead> <tbody> <tr> <td rowspan="2">Bright dot</td> <td>Any color window</td> <td>0</td> </tr> <tr> <td>Adjacent Bright dot</td> <td>0</td> </tr> <tr> <td rowspan="2">Dark dot</td> <td>Dark dot</td> <td>2</td> </tr> <tr> <td>Adjacent Dark dot</td> <td>0</td> </tr> </tbody> </table> <p>Note: the red (R), green, blue (G), (B) 3 points constitute a pixel</p>	distinguish	type	Acceptable Qty	Bright dot	Any color window	0	Adjacent Bright dot	0	Dark dot	Dark dot	2	Adjacent Dark dot	0	 <p>Dot</p>
distinguish	type	Acceptable Qty														
Bright dot	Any color window	0														
	Adjacent Bright dot	0														
Dark dot	Dark dot	2														
	Adjacent Dark dot	0														

9.2. RELIABILITY TEST

ITEM	Condition	Sample size	Criterion
High Temp. Storage	70°C, 48 hrs	5pcs	Inspection after 2~4hours storage at room temperature, the sample shall be free from defects: 1.Air bubble in the LCD; 2.Sealleak; 3.Non-display; 4.Missing segments; 5. The surface shall be free from damage. 6. Contrast must be no more than 10% by the linearity tester. 7. Power must be no more than 10% by the linearity tester.
Low Temp. Storage	-30°C, 48 hrs	5pcs	
High Temp. Operation	60°C,48 hrs	5pcs	
Low Temp. Operation	-20°C, 48 hrs	5pcs	
Humidity operation	40°C,90%RH, 48 hrs	5pcs	
Humidity storage	60°C,90%RH, 48 hrs	5pcs	
Thermal shock	-30°C/30min → 70°C/30mins Total:16cycles	5pcs	
Simulated transport	Reciprocating, 190+/-10 Ring, 2 hours, amplitude 25.4MM	1Carton-box	After testing, there are no any defective appearances or electrical properties.
Packaging drop	Six faces, Three edge (Diagonal landing), The weight and height correspond to the following 0 to 45.4KG : 80CM ; 45.4-90.8KG : 60CM ; 90.8-454KG : 45CM ; OVER454KG: 40CM	1Carton-box	
ESD	1.Contact discharge method±4KV, 150pF/330Ω 10times (Can not face the role of IC)	5pcs	1. After testing, there are no any defective appearances or electrical properties.
	2.Air discharge method±8KV,150pF/330Ω 10times (Can not face the role of IC)	5pcs	2. It can be acceptable when all defective ESD disappears in the RESET.

9.3. Safety instructions

9.3.1 If the LCD panel breaks, be careful not to get any liquid crystal substance in your mouth.

9.3.2 If the liquid crystal substance touches your skin or clothes, please wash it off immediately by using soap and water.

9.4. Handling Precautions

9.4.1 Avoid static electricity damaging the LSI.

9.4.2 Do not remove the panel or frame from the module.

9.4.3 The polarizing plate of the display is very fragile. So, please handle it very carefully.

9.4.4 Do not wipe the polarizing plate with a dry cloth, as it may easily scratch the surface of the plate.

9.4.5 The color tone of display and background of LCM has the possibility to be changed in the storage temperature range.

9.4.6 Pay attention to the working environment, as the element may be destroyed by static electricity.

--Be sure to ground human body and electric appliance during work.

--Avoid working in a dry environment to minimize the generations of static electricity.

--Static electricity may be generated when the protective film is fast peeled off.

9.4.7 When soldering the terminal of LCM, make certain the AC power source of soldering iron does not leak.

9.4.8 If the display surface becomes contaminated, breathe on the surface and gently wipe it with a soft-dry-clean cloth. If it is heavily contaminated, moisten cloth with the following solvent (ex:Ethyl alcohol).Solvents other than those above-mentioned may damage the polarizer(Especially ,do not use them .ex: Warter / Ketone)

9.5. Operation instructions

9.5.1 It is recommended to drive the LCD within the specified voltage limits, try to adjust the operating voltage for the optimal contrast, the color and contrast of LCD panel will varies at different temperature.

9.5.2 Response time is greatly delayed at low operating temperature range. However, this does not mean the LCD will be out of the order, It will recover when it returns to the specified temperature range.

9.5.3 If the display area is pushed hard during operation, the display will become abnormal.

9.5.4 Do not operate the LCD at the environments over the specified conditions, this may cause damage on the LCD and shorten the lifetime.

9.6. Storage instructions:

9.6.1 Store LCDs in a sealed polyethylene bag.

9.6.2 Store LCDs in a dark place, Do not expose to sunlight or fluorescent light. Keep the temperature between 20°C and 30°C.

9.6.3 Avoid the polarizer touch any other object, (It is recommended to store them in the container in which they were shipped.)

9.7. Limited Warranty

9.7.1 will replace or repair any of its LCD modules, which are found to be defective, when inspected in accordance with LCM acceptance standards (copies available upon request) for a period of 12 months from ink- print date on product

9.7.2 Any defects must be returned to within 60 days since ship-out. Confirmation of such date shall be based on freight documents. The warranty liability of wasam limited to repair and/or replacement on defects above (7.1,7.2)

9.7.3 No warranty can be granted if the precautions stated above have been disregarded. The typical samples are as below:

- LCD glass crack/break
- PCB outlet is damaged or modified.
- PCB conductors damaged.
- Circuit modified with by grinding, engraving or painting varnish.
- FPC crack

9.7.4 Modules must be returned with sufficient description of the failures of defects. Any connectors or cable installed by the customer must be removed completely without damaging the PCB outlet, conductors and terminals. Modules must be packed with the container in which they were shipped.



10. Packing method

Please consult our technical department for detail information.