

# AZ DISPLAYS

---

## SPECIFICATIONS FOR LIQUID CRYSTAL DISPLAY

CUSTOMER APPROVAL			
※ PART NO. : <u>AQM1016A-FLW-FTW(AZ DISPLAYS) VER1.0</u>			
APPROVAL		COMPANY CHOP	
CUSTOMER COMMENTS			

AZ DISPLAYS ENGINEERING APPROVAL		
DESIGN BY	CHECKED BY	APPROVED BY
WJQ		

**REVISION RECORD**

REVISION	REVISION DATE	PAGE	CONTENTS
VER1.0	2016-08-10		FIRST ISSUE

※ **CONTENTS**

- 1.0 MECHANICAL SPECS
- 2.0 ABSOLUTE MAXIMUM RATINGS
- 3.0 ELECTRICAL CHARACTERISTICS
- 4.0 OPTICAL CHARACTERISTICS
- 5.0 BLOCK DIAGRAM
- 6.0 PIN ASSIGNMENT
- 7.0 POWER SUPPLY
- 8.0 TIMING CHARACTERISTICS
- 9.0 MECHANICAL DRAWING
- 10.0 RELIABILITY TEST
- 11.0 DISPLAY CONTROL INSTRUCTION
- 12.0 RECOMMENDED INITIAL CODE
- 13.0 PRECAUTION FOR USING LCM

**1.0 MECHANICAL SPECS**

1. Display Format	100*160 DOTS
2. Power Supply	3.0V
3. Overall Module Size	43.5mm(W) x 57.0mm(H) x 8.7mm(D)
4. Viewing Area(W*H)	32.0mm(W) x 50.0mm(H)
5. Dot Size (W*H)	0.275mm(W) x 0.275mm(H)
6. Dot Pitch (W*H)	0.29mm(W) x 0.29mm(H)
7. Viewing Direction	12:00 O'Clock
8. Driving Method	1/100Duty,1/10Bias
9. Controller IC	ST7528 COG
10. LC Fluid Options	FSTN /Positive
11. Polarizer Options	Transflective
12. Backlight Options	LED-SIDE(WHITE)
13. Operating temperature	-10°C ~ 60°C
14. Storage temperature	-20°C ~ 70°C
15. ROHS	ROHS compliant

**2.0 ABSOLUTE MAXIMUM RATINGS**

Item	Symbol	Min	Typ	Max	Unit
Operating temperature	Top	-10	-	60	°C
Storage temperature	Tst	-20	-	70	°C
Input voltage	Vin	Vss-0.3	--	Vdd+0.3	V
Supply voltage for logic	Vdd- Vss	2.4	-	3.3	V
Supply voltage for LCD drive	Vdd- Vo	3.5	-	15	V

**3.0 ELECTRICAL CHARACTERISTICS**

**3.1 Electrical Characteristics Of LCM**

Item	Symbol	Condition	Min	Typ	Max	Unit
Power Supply Voltage	Vdd	25°C	--	3.0	--	V
Power Supply Current	Idd	Vdd=5.0V, fosc=270kHz	--	--	--	mA
Input voltage (high)	Vih	H level	0.8Vdd	--	Vdd	V
Input voltage (low)	Vil	L level	0	--	0.2Vdd	V
Recommended LC Driving Voltage	Vdd -Vo	-0°C	--	--	--	V
		25°C	--	11.0	--	
		60°C	--	--	---	

**3.2 The Characteristics Of LED Backlight**

Item	Symbol	Condition	Min	Typ	Max	Unit
Operate Current	IF	V=3.3V	--	60	--	mA
Luminance	Lv	IF= 60 mA	--	--	--	cd/m <sup>2</sup>
Peak wave length	$\Delta p$					nm
Coordinate range	x= , y=	IF= 60 mA -	x= 0.26~0.30 , y= 0.27~0.31			

**Note:** i. Luminance means the backlight brightness without glass.

**4.0 OPTICAL CHARACTERISTICS (Ta=25°C, Vdd= 3.0V±0.2V)**

Item	Symbol	Condition	Min	Typ	Max	Unit
Viewing angle (horizontal)	$\theta$	Cr ≥ 2.0	-35	-	35	deg
Viewing angle (vertical)	$\phi$	Cr ≥ 2.0	-25	-	40	deg
Contrast Ratio	Cr	$\phi=0^\circ, \theta=0^\circ$	-	6	-	
Response time (rise)	Tr	$\phi=0^\circ, \theta=0^\circ$	-	180	300	ms
Response time (fall)	Tf	$\phi=0^\circ, \theta=0^\circ$	-	150	250	ms

**(1). Definition of Optical Response Time**

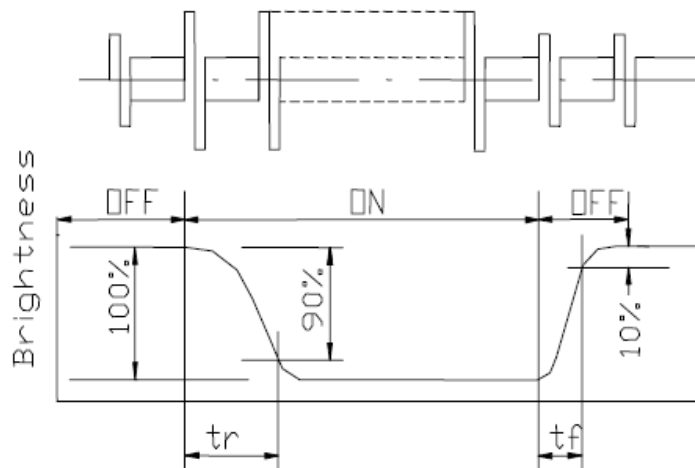

**(2). Definition of Contrast Ratio**

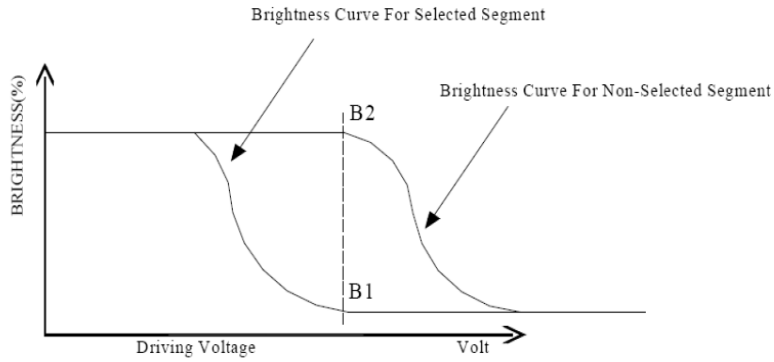

$$C_r = \frac{\text{Brightness of Non-selected Segment}(B2)}{\text{Brightness of selected Segment}(B1)}$$

**(3). Definition of Viewing Angle  $\theta$  and  $\Phi$**

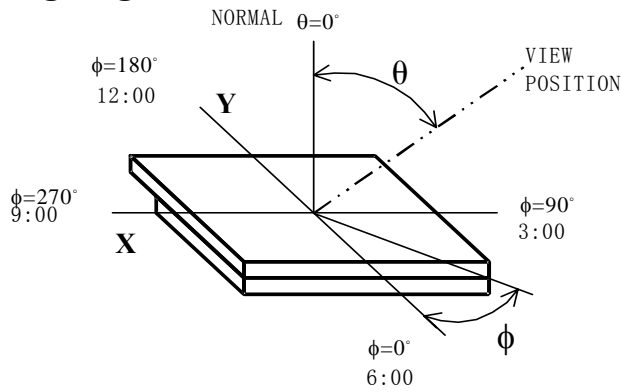

**5.0 BLOCK DIAGRAM**

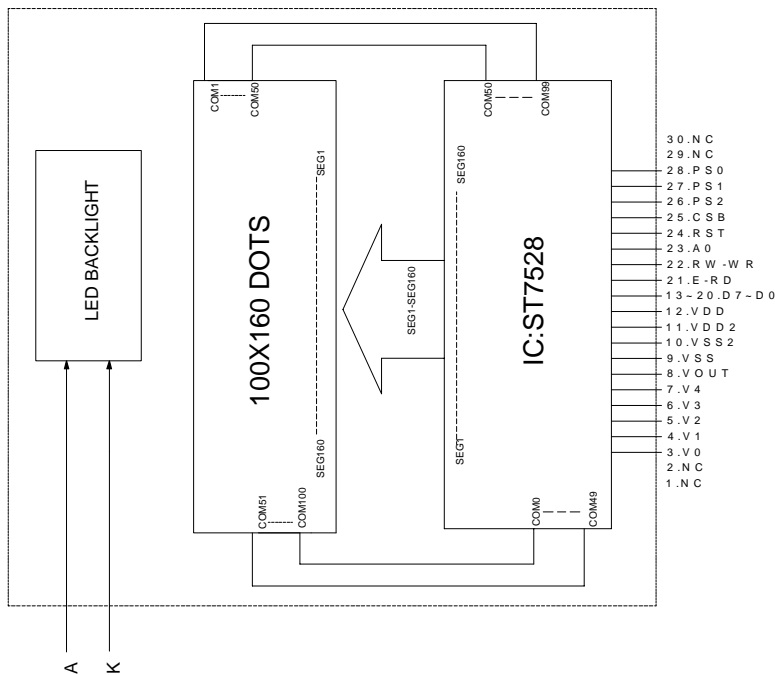

## 6.0 PIN ASSIGNMENT

Pin No.	Symbol	Function
1~2	NC	--
3	V0	LCD driver supply voltages
4	V1	
5	V2	
6	V3	
7	V4	
8	VOUT	DC/DC voltage converter
9	VSS	Ground
10	VSS2	Ground
11	VDD2	Power Supply
12	VDD	Power Supply
13	D7	Data bus
14	D6	
15	D5	
16	D4	
17	D3	
18	D2	
19	D1	
20	D0	
21	E-RD	Read / Write execution control pin
22	RW-WR	Read / Write execution control pin
23	A0	Register select input pin
24	RST	Reset input pin
25	CSB	Chip select input pins
26	PS2	Parallel / Serial data input select input
27	PS1	
28	PS0	
29~30	NC	--

## 7.0 POWER SUPPLY

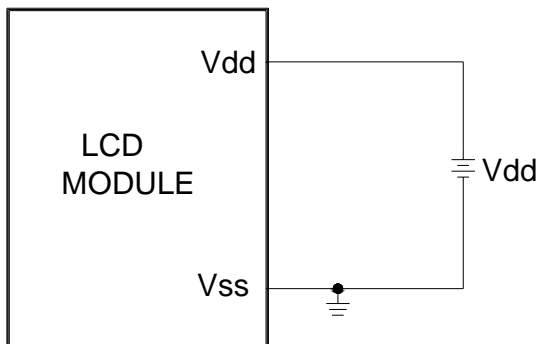

## 8.0 TIMING CHARACTERISTICS

### System Bus Read/Write Characteristics 1 (For the 8080 Series MPU)

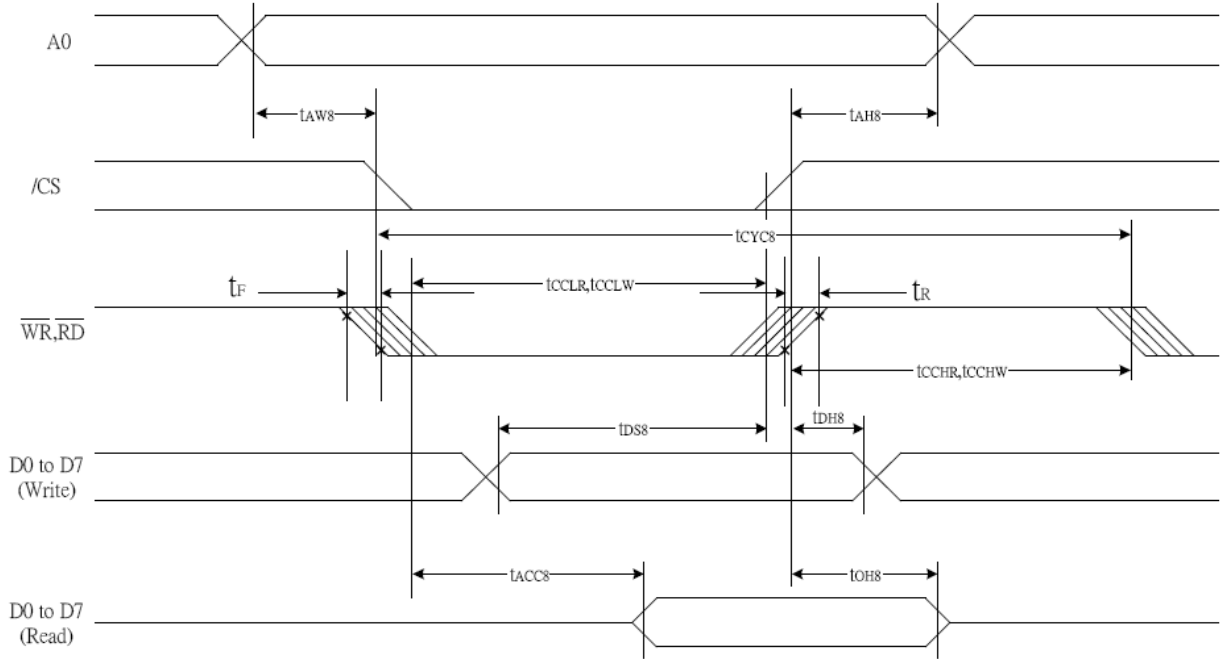

Figure 26.

(VDD = 3.3V , Ta = -30-85 °C)

Item	Signal	Symbol	Condition	Rating		Units	
				Min.	Max.		
Address hold time	A0	tAH8		0	—	ns	
Address setup time		tAW8		0	—		
System cycle time		tCYC8		240	—		
Enable L pulse width (WRITE)	WR	tCCLW		80	—		
Enable H pulse width (WRITE)		tCCHW		80	—		
Enable L pulse width (READ)	RD	tCCLR		140	—		
Enable H pulse width (READ)		tCCHR		80	—		
WRITE Data setup time	D0 to D7	tDS8		40	—		
WRITE Data hold time		tDH8		10	—		
READ access time		tACC8	CL = 100 pF	—	70		
READ Output disable time		tOH8	CL = 100 pF	5	50		
tF				—	10		
tR				—	10		



## AQM1016A-FLW-FTW(AZ DISPLAYS) GRAPHIC MODULE VER1.0

(VDD = 2.7 V , Ta = -30~85°C )

Item	Signal	Symbol	Condition	Rating		Units
				Min.	Max.	
Address hold time	A0	tAH8		0	—	ns
Address setup time		tAW8		0	—	
System cycle time		tCYC8		400	—	
Enable L pulse width (WRITE)	WR	tCCLW		220	—	
Enable H pulse width (WRITE)		tCCHW		180	—	
Enable L pulse width (READ)	RD	tCCLR		220	—	
Enable H pulse width (READ)		tCCHR		180	—	
WRITE Data setup time	D0 to D7	tDS8		40	—	
WRITE Data hold time		tDH8		15	—	
READ access time		tACC8	CL = 100 pF	—	140	
READ Output disable time		tOH8	CL = 100 pF	10	100	
tF				—	10	
tR				—	10	

(VDD = 1.8V , Ta = -30~85°C )

Item	Signal	Symbol	Condition	Rating		Units
				Min.	Max.	
Address hold time	A0	tAH8		0	—	ns
Address setup time		tAW8		0	—	
System cycle time		tCYC8		640	—	
Enable L pulse width (WRITE)	WR	tCCLW		360	—	
Enable H pulse width (WRITE)		tCCHW		280	—	
Enable L pulse width (READ)	RD	tCCLR		360	—	
Enable H pulse width (READ)		tCCHR		280	—	
WRITE Data setup time	D0 to D7	tDS8		80	—	
WRITE Data hold time		tDH8		30	—	
READ access time		tACC8	CL = 100 pF	—	240	
READ Output disable time		tOH8	CL = 100 pF	10	200	
tF				—	10	
tR				—	10	

\*1 The input signal rise time and fall time (tr, tf) is specified at 15 ns or less. When the system cycle time is extremely fast, (tr + tf) ≤ (tCYC8 – tCCLW – tCCHW) for (tr + tf) ≤ (tCYC8 – tCCLR – tCCHR) are specified.

\*2 All timing is specified using 20% and 80% of VDD as the reference.

\*3 tCCLW and tCCLR are specified as the overlap between CSB being "L" and WR and RD being at the "L" level.

# AQM1016A-FLW-FTW(AZ DISPLAYS) GRAPHIC MODULE VER1.0

## System Bus Read/Write Characteristics 1 (For the 6800 Series MPU)

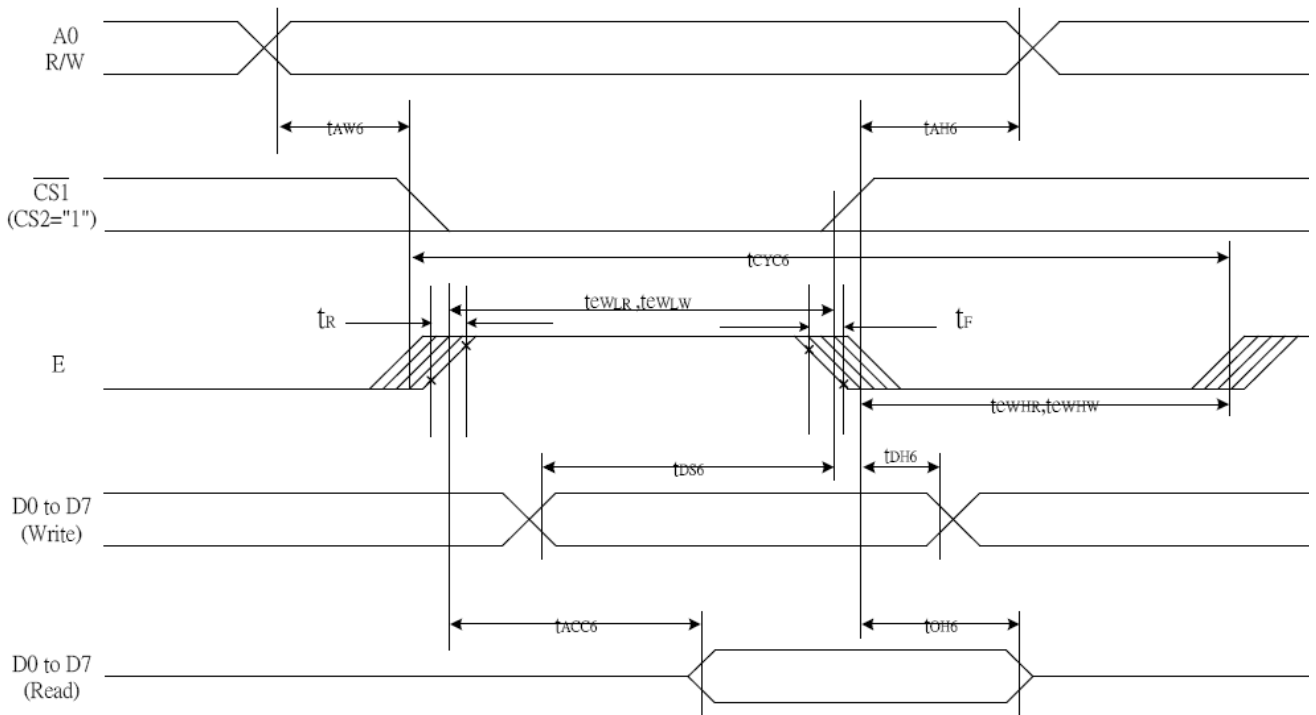

Figure 30

(V<sub>DD</sub> = 3.3 V, T<sub>a</sub> = -30~85°C )

Item	Signal	Symbol	Condition	Rating		Units
				Min.	Max.	
Address hold time	A0	tAH6		0	—	ns
Address setup time		tAW6		0	—	
System cycle time		tCYC6		240	—	
Enable L pulse width (WRITE)	E_WR	tEWLW		80	—	
Enable H pulse width (WRITE)		tEWHW		80	—	
Enable L pulse width (READ)	E_RD	tEWLRL		80	—	
Enable H pulse width (READ)		tEWHRL		140	—	
WRITE Data setup time	D0 to D7	tDS6		40	—	
WRITE Data hold time		tDH6		10	—	
READ access time		tACC6	CL = 100 pF	—	70	
READ Output disable time		tOH6	CL = 100 pF	5	50	
tF				—	10	
tR				—	10	

**AQM1016A-FLW-FTW(AZ DISPLAYS) GRAPHIC MODULE VER1.0**

(VDD = 2.7V, Ta = -30~85 °C )

Item	Signal	Symbol	Condition	Rating		Units
				Min.	Max.	
Address hold time	A0	tAH6		0	—	ns
Address setup time		tAW6		0	—	
System cycle time		tCYC6		400	—	
Enable L pulse width (WRITE)	WR	tEWLW		220	—	
Enable H pulse width (WRITE)		tEWHW		180	—	
Enable L pulse width (READ)	RD	tEWLR		220	—	
Enable H pulse width (READ)		tEWHR		180	—	
WRITE Data setup time	D0 to D7	tDS6		40	—	
WRITE Data hold time		tDH6		15	—	
READ access time		tACC6	CL = 100 pF	—	140	
READ Output disable time		tOH6	CL = 100 pF	10	100	
tF				—	10	
tR				—	10	

(VDD = 1.8V, Ta = -30~85 °C )

Item	Signal	Symbol	Condition	Rating		Units
				Min.	Max.	
Address hold time	A0	tAH6		0	—	ns
Address setup time		tAW6		0	—	
System cycle time		tCYC6		640	—	
Enable L pulse width (WRITE)	WR	tEWLW		360	—	
Enable H pulse width (WRITE)		tEWHW		280	—	
Enable L pulse width (READ)	RD	tEWLR		360	—	
Enable H pulse width (READ)		tEWHR		280	—	
WRITE Data setup time	D0 to D7	tDS6		80	—	
WRITE Data hold time		tDH6		30	—	
READ access time		tACC6	CL = 100 pF	—	240	
READ Output disable time		tOH6	CL = 100 pF	10	200	
tF				—	10	
tR				—	10	

\*1 The input signal rise time and fall time (tr, tf) is specified at 15 ns or less. When the system cycle time is extremely fast, (tr + tf) ≤ (tCYC6 – tEWLW – tEWHW) for (tr + tf) ≤ (tCYC6 – tEWLR – tEWHR) are specified.

\*2 All timing is specified using 20% and 80% of VDD as the reference.

\*3 tEWLW and tEWLR are specified as the overlap between CSB being "L" and E.

9.0 MECHANICAL DRAWING

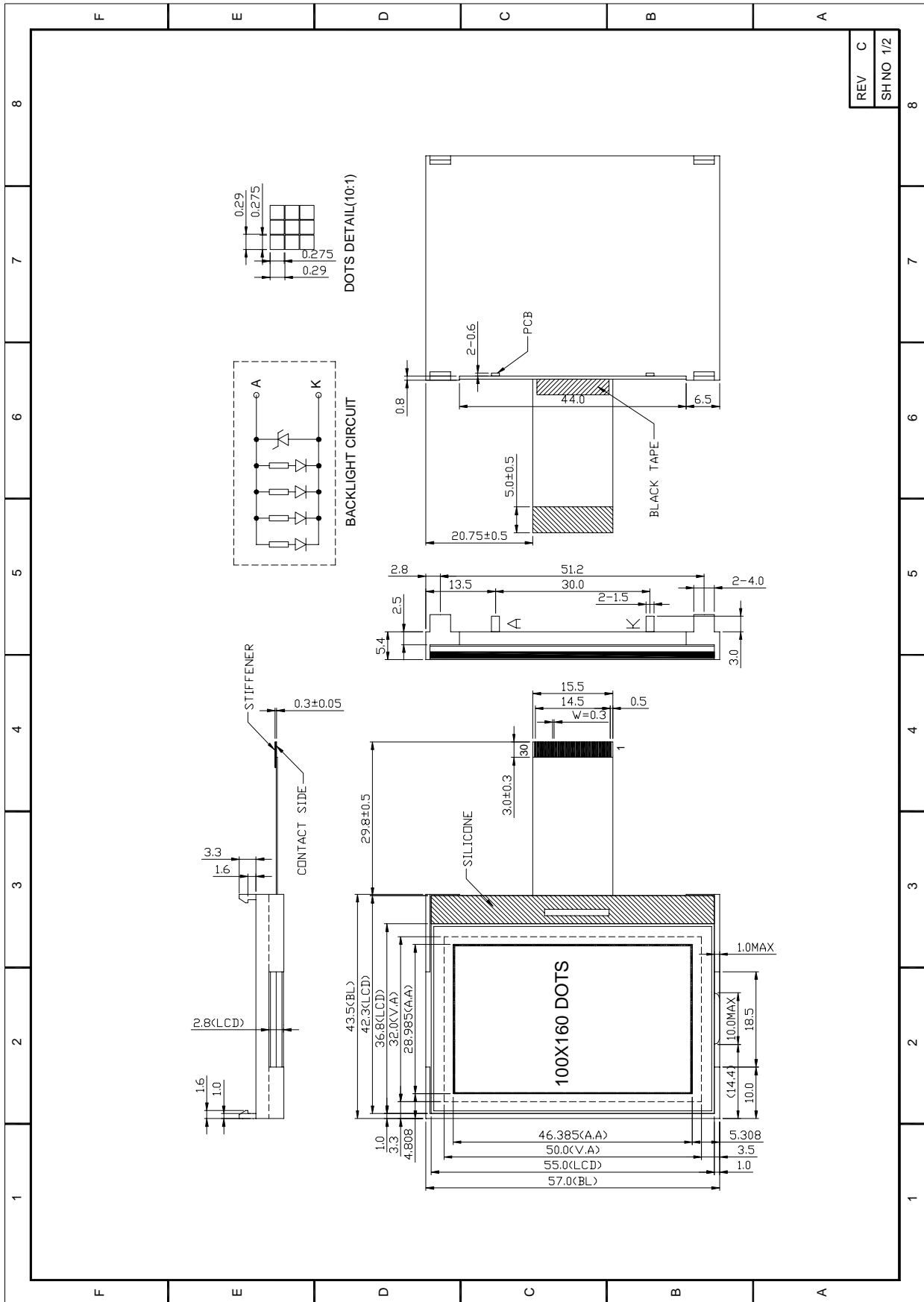

REV	C
SH NO	1/2

AQM1016A-FLW-FTW(AZ DISPLAYS) GRAPHIC MODULE VER1.0

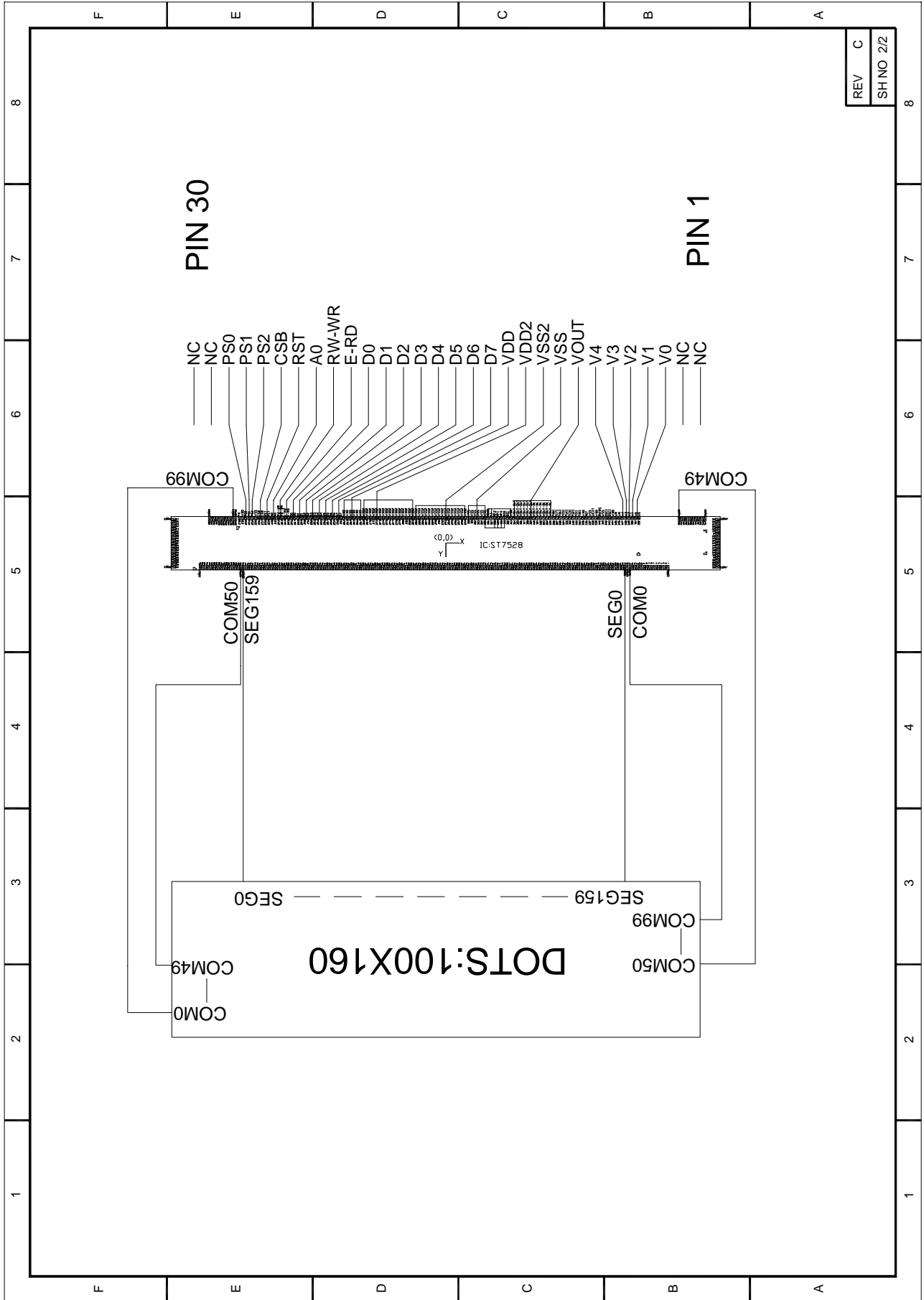

**10.0 RELIABILITY TEST**

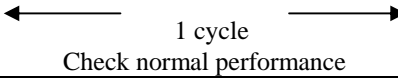
NO	Test Item	Description	Test Condition	Remark	
1	Environmental Test	High temperature storage	Applying the high storage temperature Under normal humidity for a long time Check normal performance	70 °C 96hrs	
2		Low temperature storage	Applying the low storage temperature Under normal humidity for a long time Check normal performance	-20°C 96hrs	
3		High temperature Operation	Apply the electric stress(Volatge and current) Under high temperature for a long time	60 °C 96hrs	Note1
4		Low temperature Operation	Apply the electric stress Under low temperature for a long time	-10°C 96hrs	Note1 Note2
5		High temperature/High Humidity Storage	Apply high temperature and high humidity storage for a long time	90% RH 40°C 96hrs	Note2
6		Temperature Cycle	Apply the low and high temperature cycle -20°C <> 25°C <> 70°C <> 25°C 30min 10min 30min 10min  Check normal performance	-20°C/70°C 10 cycle	
7	Mechanical Test	Vibration test(Package state)	Applying vibration to product check normal performance	Freq:10-55Hz Max Acceleration 5G 1cycle time:1min time X.Y.Z direction for 15 mines	
8		Shock test(package state)	Applying shock to product check normal performance	Drop them through 70cm height to strike horizontal plane	
9	Other				

**Remark**

Note1:Normal operations condition (25°C±5°C).

Note2:Pay attention to keep dewdrops from the module during this test.

## 11.0 DISPLAY CONTROL INSTRUCTION

Instruction	A0	RW	DB7	DB6	DB5	DB4	DB3	DB2	DB1	DB0	Description
<b>EXT=0 or 1</b>											
Mode Set	0	0	0	0	1	1	1	0	0	0	2-byte instruction to set Mode and FR( Frame frequency control) BE( Booster efficiency control)
	0	0	FR3	FR2	FR1	FR0	0	BE	x'	EXT	
<b>EXT=0</b>											
Read display data	1	1	Read data							Read data into DDRAM	
Write display data	1	0	Write data							Write data into DDRAM	
Read status	0	1	BUSY	ON	RES	MF2	MF1	MF0	DS1	DS0	Read the internal status
ICON control register ON/OFF	0	0	1	0	1	0	0	0	1	ICON	ICON=0: ICON disable(default) ICON=1: ICON enable & set the page address to 16
Set page address	0	0	1	0	1	1	P3	P2	P1	P0	Set page address
Set column address MSB	0	0	0	0	0	1	Y9	Y8	Y7	Y6	Set column address MSB
Set column address LSB	0	0	0	0	0	0	Y5	Y4	Y3	Y2	Set column address LSB
Set modify-read	0	0	1	1	1	0	0	0	0	0	Set modify-read mode
Reset modify-read	0	0	1	1	1	0	1	1	1	0	release modify-read mode
Display ON/OFF	0	0	1	0	1	0	1	1	1	D	D=0: Display OFF D=1: Display ON
Set initial display line register	0	0	0	1	0	0	0	0	x'	x'	2-byte instruction to specify the initial display line to realize vertical scrolling
	0	0	x'	S6	S5	S4	S3	S2	S1	S0	
Set initial COM0 register	0	0	0	1	0	0	0	1	x'	x'	2-byte instruction to specify the initial COM0 to realize window scrolling
	0	0	x'	C6	C5	C4	C3	C2	C1	C0	
Select partial display line	0	0	0	1	0	0	1	0	x'	x'	2-byte instruction to set partial display ratio
	0	0	D7	D6	D5	D4	D3	D2	D1	D0	
Set N-line inversion	0	0	0	1	0	0	1	1	x'	x'	2-byte instruction to set N-line inversion register
	0	0	x'	x'	x'	N4	N3	N2	N1	N0	
Release N-line inversion	0	0	1	1	1	0	0	1	0	0	Release N-line inversion mode
Reverse display ON/OFF	0	0	1	0	1	0	0	1	1	REV	REV=0: normal display REV=1: reverse display
Entire display ON/OFF	0	0	1	0	1	0	0	1	0	EON	EON=0: normal display EON=1: entire display ON

**AQM1016A-FLW-FTW(AZ DISPLAYS) GRAPHIC MODULE VER1.0**

Instruction	A0	RW	DB7	DB6	DB5	DB4	DB3	DB2	DB1	DB0	Description
<b>Ext=0</b>											
Power control	0	0	0	0	1	0	1	VC	VR	VF	Control power circuit operation
Select DC-DC step-up	0	0	0	1	1	0	0	1	DC1	DC0	Select the step-up of internal voltage converter
Select regulator register	0	0	0	0	1	0	0	R2	R1	R0	Select the internal resistance ratio of the regulator resistor
Select electronic volumn register	0	0	1	0	0	0	0	0	0	1	2-byte instruction to specify the reference voltage
	0	0	x'	x'	EV5	EV4	EV3	EV2	EV1	EV0	
Select LCD bias	0	0	0	1	0	1	0	B2	B1	B0	Select LCD bias
Set Bias Power Save Mode	0	0	1	1	1	1	0	0	1	1	Bias Power save Save the Bias current consumption
	0	0	0	0	0	0	0	0	0	0	
Release Bias Power Save Mode	0	0	1	1	1	1	0	0	1	1	Bias Power save release set the Bias power to normal
	0	0	0	0	0	0	0	1	0	0	
SHL select	0	0	1	1	0	0	SHL	x'	x'	x'	COM bi-directional selection SHL=0: normal direction SHL=1: reverse direction
ADC select	0	0	1	0	1	0	0	0	0	ADC	SEG bi-direction selection ADC=0: normal direction ADC=1: reverse direction
Oscillator on start	0	0	1	0	1	0	1	0	1	1	Start the built-in oscillator
Set power save mode	0	0	1	0	1	0	1	0	0	P	P=0: normal mode P=1: sleep mode
Release power save mode	0	0	1	1	1	0	0	0	0	1	release power save mode
Reset	0	0	1	1	1	0	0	0	1	0	initial the internal function
Set data direction & display data length(DDL)	x'	x'	1	1	1	0	1	0	0	0	2-byte instruction to specify the number of data bytes. (SPI mode)
	x'	x'	D7	D6	D5	D4	D3	D2	D1	D0	
Select FRC and PWM mode	0	0	1	0	0	1	0	FRC	PWM1	PWM0	FRC(1:3FRC, 0:4FRC) PWM1 PWM0 0 0 45PWM 0 1 45 PWM 1 0 60PWM 1 1 ---
NOP	0	0	1	1	1	0	0	0	1	1	<i>No operation</i>
Test Instruction	0	0	1	1	1	1	x'	x'	x'	x'	<i>Don't use this instruction</i>



## 12.0 RECOMMENDED INITIAL CODE

```
void st7528_1016_inilcd(void) //初始化子程序
{
    st7528_1016_cs=0;
    st7528_1016_ps0=1;
    st7528_1016_delay(1);
    st7528_1016_ps1=0;
    st7528_1016_ps2=0;
    st7528_1016_rst=0;
    st7528_1016_delay(1);
    st7528_1016_rst=1;
    st7528_1016_delay(1);
    st7528_1016_writecommand(0xa2);
    st7528_1016_writecommand(0xae);
    st7528_1016_writecommand(0x40);
    st7528_1016_writecommand(0x00);
    st7528_1016_writecommand(0x48);
    st7528_1016_writecommand(0x00);
    st7528_1016_writecommand(0xa0);
    st7528_1016_writecommand(0xc8);)
    st7528_1016_writecommand(0x44);
    st7528_1016_writecommand(0x00);
    st7528_1016_writecommand(0xab);
    st7528_1016_writecommand(0x64);
    st7528_1016_delay(1);
    st7528_1016_writecommand(0x65);
    st7528_1016_delay(1);
    st7528_1016_writecommand(0x66);
    st7528_1016_delay(1);
    st7528_1016_writecommand(0x25);
    st7528_1016_writecommand(0x81);
    st7528_1016_writecommand(0x2C);
    st7528_1016_writecommand(0x55);
    st7528_1016_writecommand(0x92);
```





## AQM1016A-FLW-FTW(AZ DISPLAYS) GRAPHIC MODULE VER1.0

---

```
st7528_1016_writecommand(0x9c);  
st7528_1016_writecommand(35);  
st7528_1016_writecommand(0x9d);  
st7528_1016_writecommand(35);  
st7528_1016_writecommand(0x9e);  
st7528_1016_writecommand(35);  
st7528_1016_writecommand(0x9f);  
st7528_1016_writecommand(35);
```

///*0xa0*

```
st7528_1016_writecommand(0xa0);  
st7528_1016_writecommand(39);  
st7528_1016_writecommand(0xa1);  
st7528_1016_writecommand(39);  
st7528_1016_writecommand(0xa2);  
st7528_1016_writecommand(39);  
st7528_1016_writecommand(0xa3);  
st7528_1016_writecommand(39);  
st7528_1016_writecommand(0xa4);  
st7528_1016_writecommand(43);  
st7528_1016_writecommand(0xa5);  
st7528_1016_writecommand(43);  
st7528_1016_writecommand(0xa6);  
st7528_1016_writecommand(43);  
st7528_1016_writecommand(0xa7);  
st7528_1016_writecommand(43);  
st7528_1016_writecommand(0xa8);  
st7528_1016_writecommand(47);  
st7528_1016_writecommand(0xa9);  
st7528_1016_writecommand(47);  
st7528_1016_writecommand(0xaa);  
st7528_1016_writecommand(47);  
st7528_1016_writecommand(0xab);  
st7528_1016_writecommand(47);  
st7528_1016_writecommand(0xac);
```



```
st7528_1016_writecommand(0xbd);  
  
st7528_1016_writecommand(60);  
  
st7528_1016_writecommand(0xbe);  
  
st7528_1016_writecommand(60);  
  
st7528_1016_writecommand(0xbf);  
  
st7528_1016_writecommand(60);  
  
st7528_1016_writecommand(0x38);  
  
st7528_1016_writecommand(0x64);  
  
st7528_1016_writecommand(0xaf);  
  
st7528_1016_delay(1);  
  
}
```

### **13.0 PRECAUTION FOR USING LCM**

1. When design the product with this LCD Module, make sure the viewing angle matches to its purpose of usage.
2. As LCD panel is made of glass substrate, Dropping the LCD module or banging it against hard objects may cause cracking or fragmentation. Especially at corners and edges.
3. Although the polarizer of this LCD Module has the anti-glare coating, always be careful not to scratch its surface. Use of a plastic cover is recommended to protect the surface of polarizer.
4. If the LCD module is stored at below specified temperature, the LC material may freeze and be deteriorated. If it is stored at above specified temperature, the molecular orientation of the LC material may change to Liquid state and it may not revert to its original state. Excessive temperature and humidity could cause polarizer peel off or bubble. Therefore, the LCD module should always be stored within specified temperature range.
5. Saliva or water droplets must be wiped off immediately as those may leave stains or cause color changes if remained for a long time. Water vapor will cause corrosion of ITO electrodes.
6. If the surface of LCD panel needs to be cleaned, wipe it swiftly with cotton or other soft cloth. If it is not still clean enough, blow a breath on the surface and wipe again.
7. The module should be driven according to the specified ratings to avoid malfunction and permanent damage. Applying DC voltage cause a rapid deterioration of LC material. Make sure to apply alternating waveform by continuous application of the M signal. Especially the power ON/OFF sequence should be kept to avoid latch-up of driver LSIs and DC charge up to LCD panel.
8. Mechanical Considerations
  - a) LCM are assembled and adjusted with a high degree of precision. Avoid excessive shocks and do not make any alterations or modifications. The following should be noted.
  - b) Do not tamper in any way with the tabs on the metal frame.
  - c) Do not modify the PCB by drilling extra holes, changing its outline, moving its components or modifying its pattern.
  - d) Do not touch the elastomer connector; especially insert a backlight panel (for example, EL).
  - e) When mounting a LCM makes sure that the PCB is not under any stress such as bending or twisting. Elastomer contacts are very delicate and missing pixels could result from slight dislocation of any of the elements.
  - f) Avoid pressing on the metal bezel, otherwise the elastomer connector could be deformed and lose contact, resulting in missing pixels.
9. Static Electricity
  - a) Operator

**Ware the electrostatics shielded clothes because human body may be statically charged if not ware shielded clothes. Never touch any of the conductive parts such as the LSI pads; the copper leads on the PCB and the interface terminals with any parts of the human body.**

- b) Equipment

There is a possibility that the static electricity is charged to the equipment, which has a function of peeling or friction action (ex: conveyer, soldering iron, working table). Earth the equipment through proper resistance (electrostatic earth:  $1 \times 10^8$  ohm).

Only properly grounded soldering irons should be used.

If an electric screwdriver is used, it should be well grounded and shielded from commutator sparks.

The normal static prevention measures should be observed for work clothes and working benches; for the latter conductive (rubber) mat is recommended.

c) Floor

**Floor is the important part to drain static electricity, which is generated by operators or equipment.**

There is a possibility that charged static electricity is not properly drained in case of insulating floor. Set the electrostatic earth (electrostatic earth:  $1 \times 10^8$  ohm).

d) Humidity

Proper humidity helps in reducing the chance of generating electrostatic charges. Humidity should be kept over 50%RH.

e) Transportation/storage

**The storage materials also need to be anti-static treated because there is a possibility that the human body or storage materials such as containers may be statically charged by friction or peeling.**

The modules should be kept in antistatic bags or other containers resistant to static for storage.

f) Soldering

Solder only to the I/O terminals. Use only soldering irons with proper grounding and no leakage.

Soldering temperature :  $280^{\circ} \text{C} \pm 10^{\circ} \text{C}$

Soldering time: 3 to 4 sec.

Use eutectic solder with resin flux fill.

If flux is used, the LCD surface should be covered to avoid flux spatters. Flux residue should be removed afterwards.

g) Others

**The laminator (protective film) is attached on the surface of LCD panel to prevent it from scratches or stains. It should be peeled off slowly using static eliminator.**

Static eliminator should also be installed to the workbench to prevent LCD module from static charge.

### 10. Operation

a) Driving voltage should be kept within specified range; excess voltage shortens display life.

b) Response time increases with decrease in temperature.

c) Display may turn black or dark blue at temperatures above its operational range; this is (however not pressing on the viewing area) may cause the segments to appear "fractured".

d) Mechanical disturbance during operation (such as pressing on the viewing area) may cause the segments to appear "fractured".

11. If any fluid leaks out of a damaged glass cell, wash off any human part that comes into contact with soap and water. The toxicity is extremely low but caution should be exercised at all the time.

12. Disassembling the LCD module can cause permanent damage and it should be strictly avoided.

13. LCD retains the display pattern when it is applied for long time (Image retention). To prevent image retention, do not apply the fixed pattern for a long time. Image retention is not a deterioration of LCD. It will be removed after display pattern is changed.

14. Do not use any materials, which emit gas from epoxy resin (hardener for amine) and silicone adhesive agent (dealcohol or deoxym) to prevent discoloration of polarizer due to gas.

15. Avoid the exposure of the module to the direct sunlight or strong ultraviolet light for a long time.

The brightness of LCD module may be affected by the routing of CCFL cables due to leakage to the chassis

through coupling effect. The inverter circuit needs to be designed taking the level of leakage current into

consideration. Thorough evaluation is needed for LCD module and inverter built into its host equipment to ensure specified brightness.