

DRAM-DLL

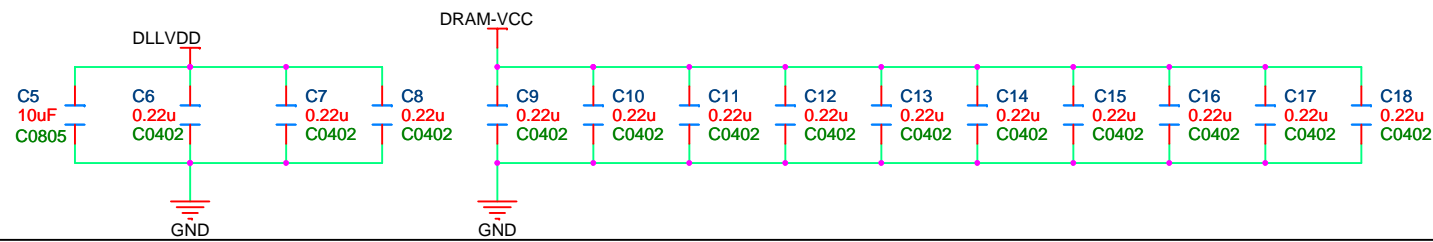

PLL-NAND

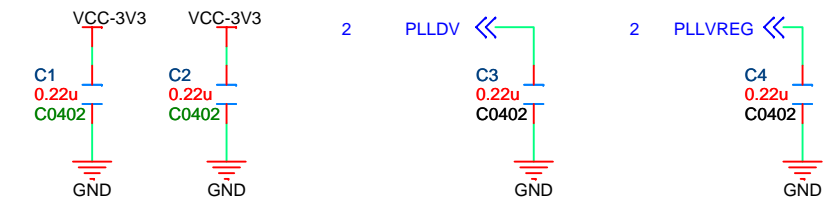

CRYSTAL

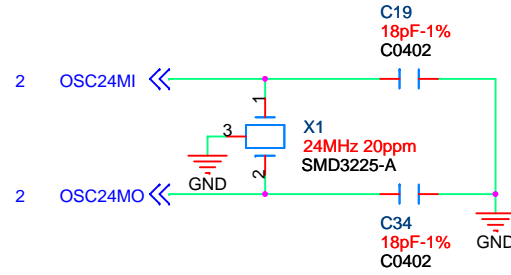

CORE

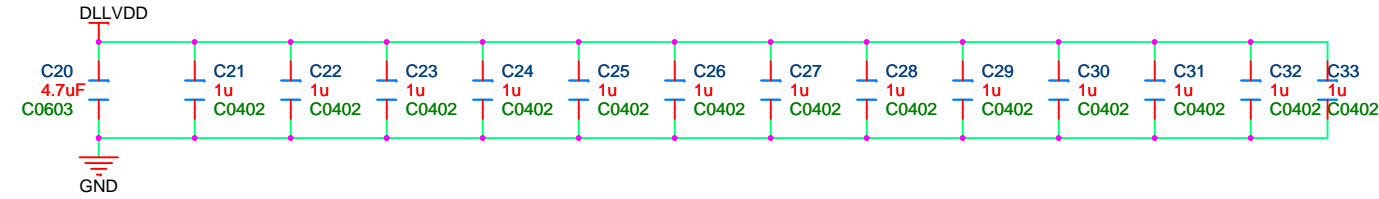

AUDIO-LRADC

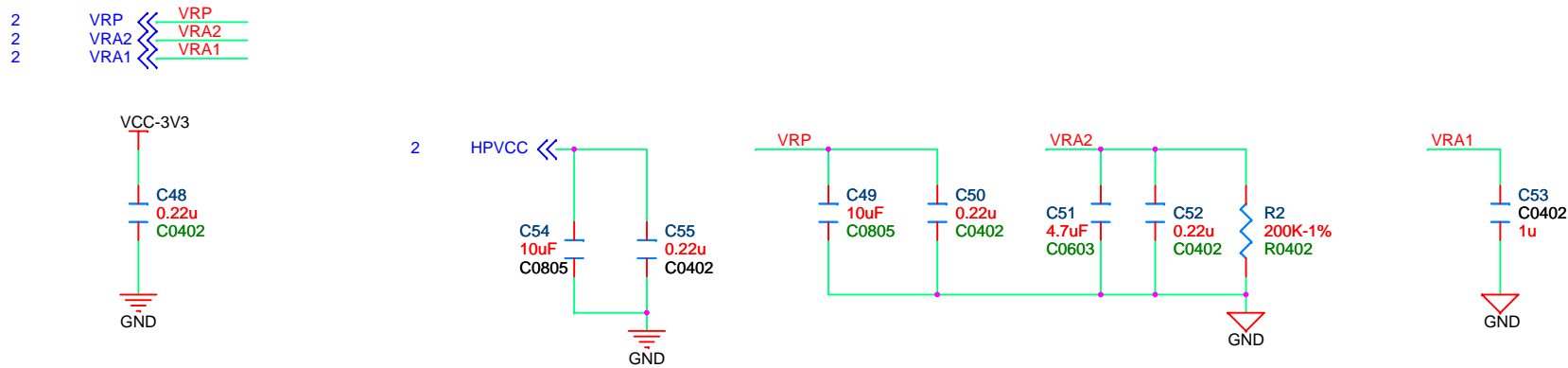

PIO-INTFACE

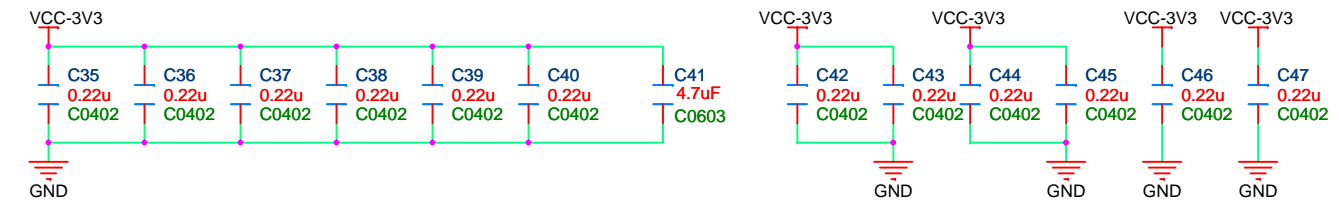

CPU

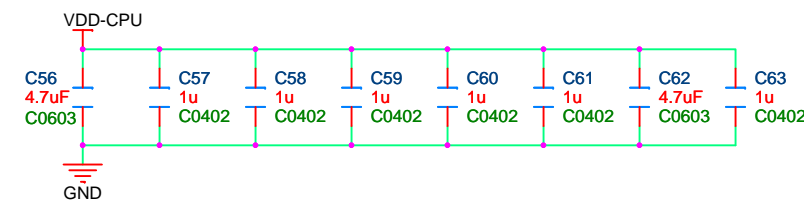

USB-TV-CSI

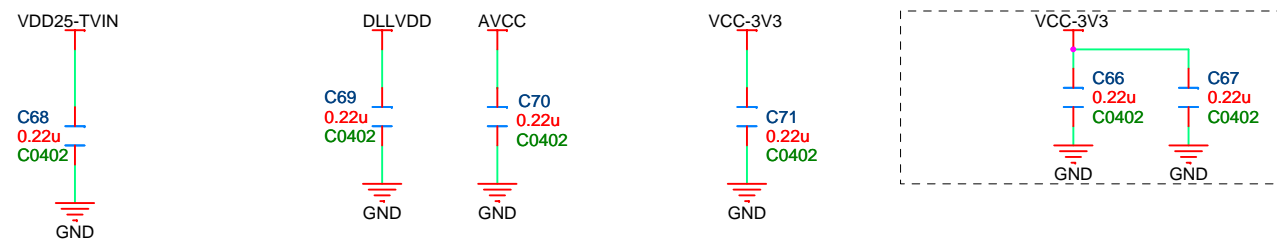

RESET-RTC

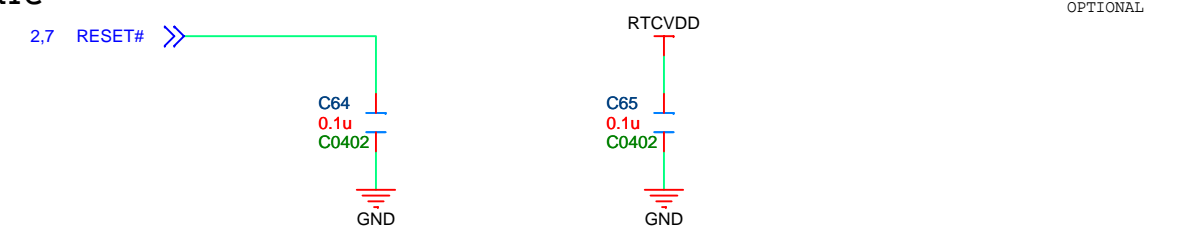

HDMI

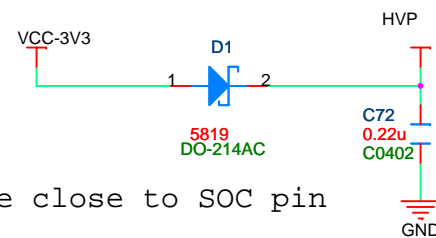

place close to SOC pin

OTHERS

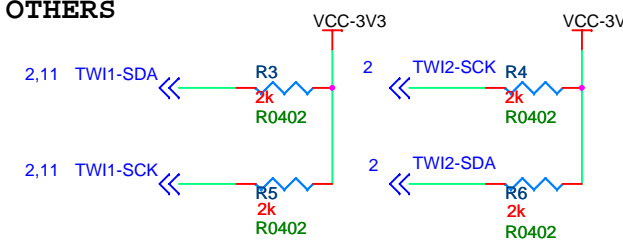

Title		
AZD-A7N-1GB Document		
Size	Number	Document
A3	Number	<Doc><Doc><Doc>
Date:	Sheet	3 of 11
	Rev	V1.0

DDR3

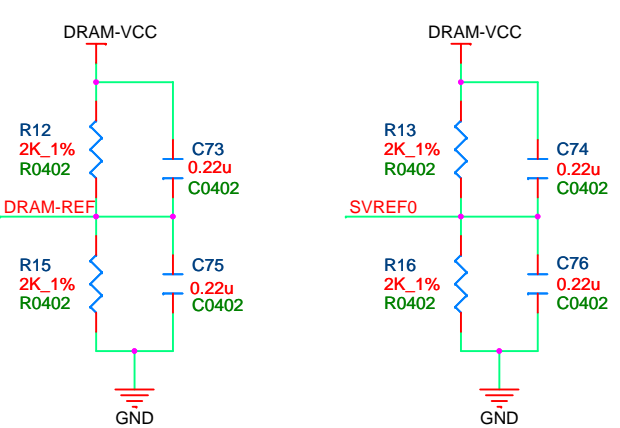
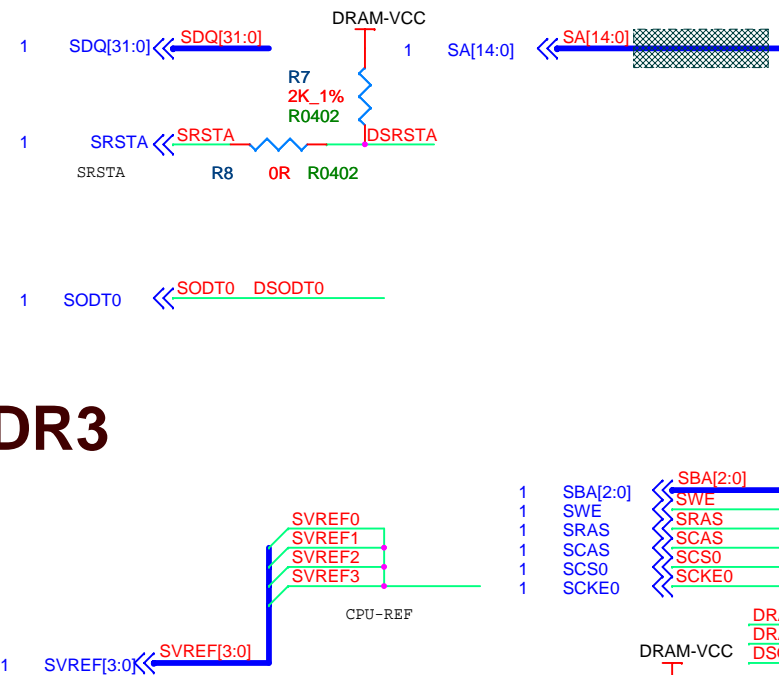

Differential pairs
Z0= 100 ohm

Equilateral BUS
Z0= 50 ohm

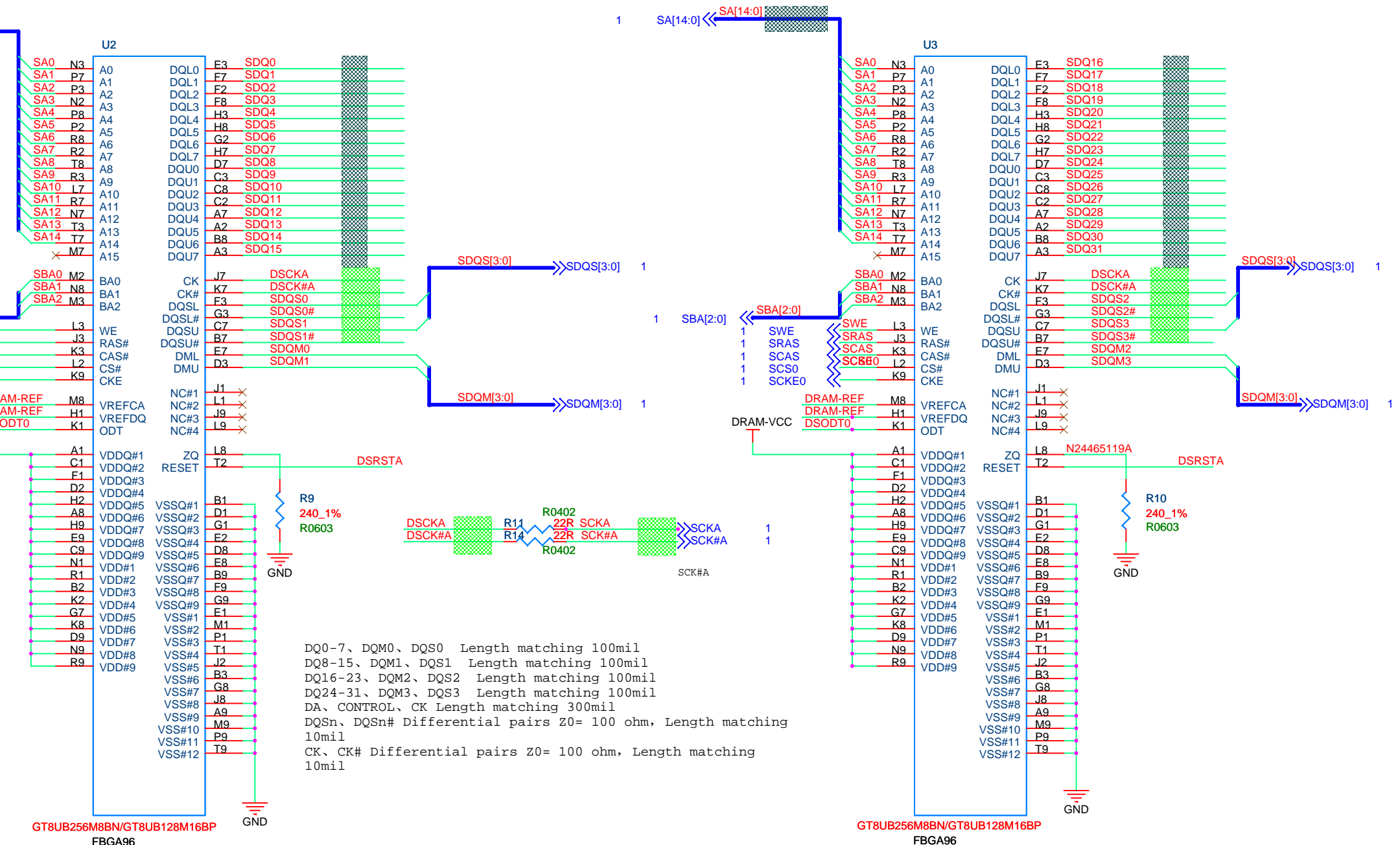

DQ0-7, DQM0, DQS0 Length matching 100mil
 DQ8-15, DQM1, DQS1 Length matching 100mil
 DQ16-23, DQM2, DQS2 Length matching 100mil
 DQ24-31, DQM3, DQS3 Length matching 100mil
 DA, CONTROL, CK Length matching 300mil
 DQSn, DQSn# Differential pairs Z0= 100 ohm, Length matching 10mil
 CK, CK# Differential pairs Z0= 100 ohm, Length matching 10mil

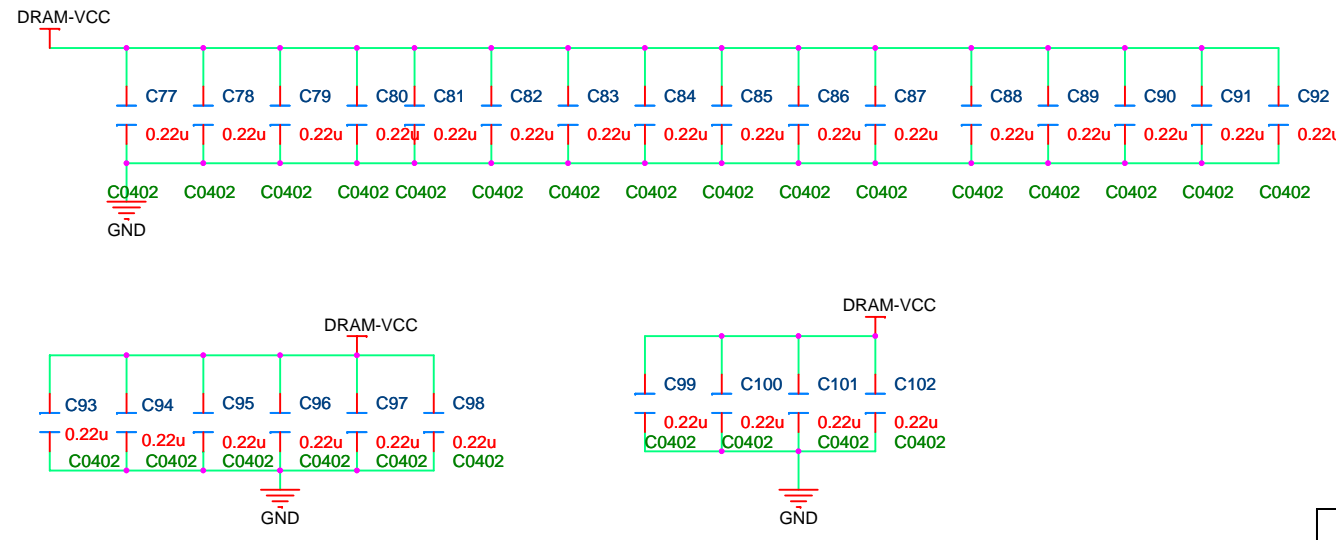

CARD0

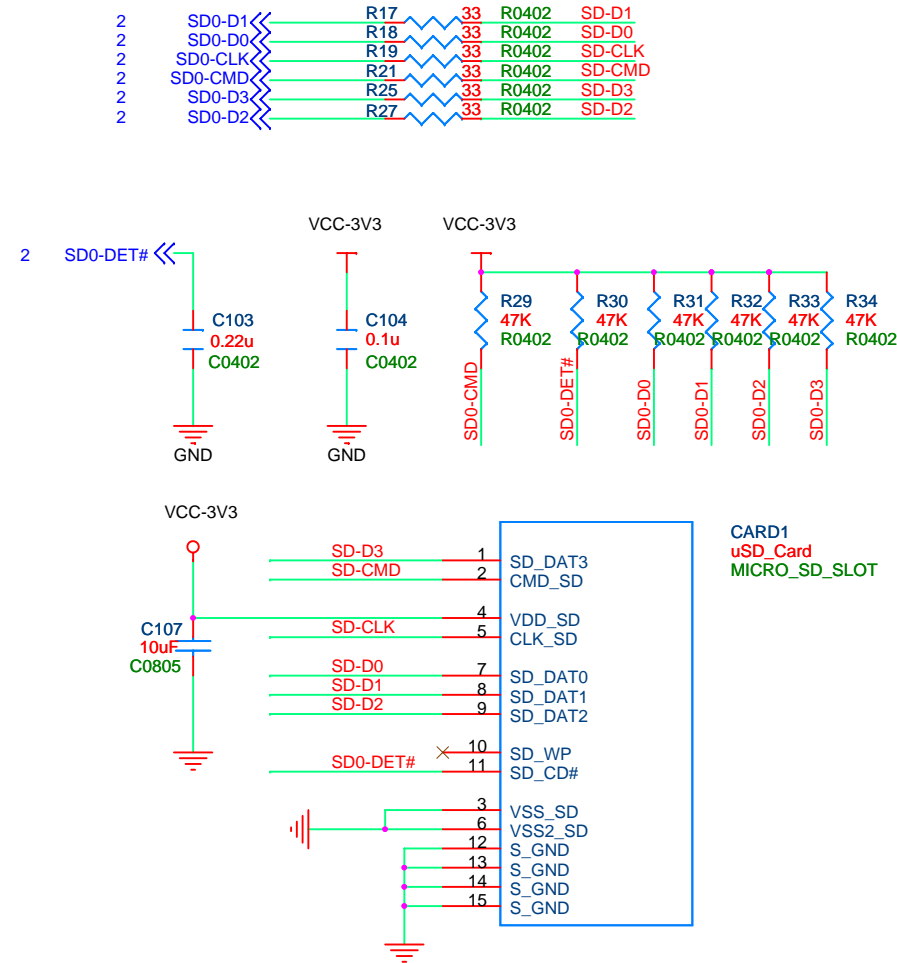

CARD2 (option with NAND flash)

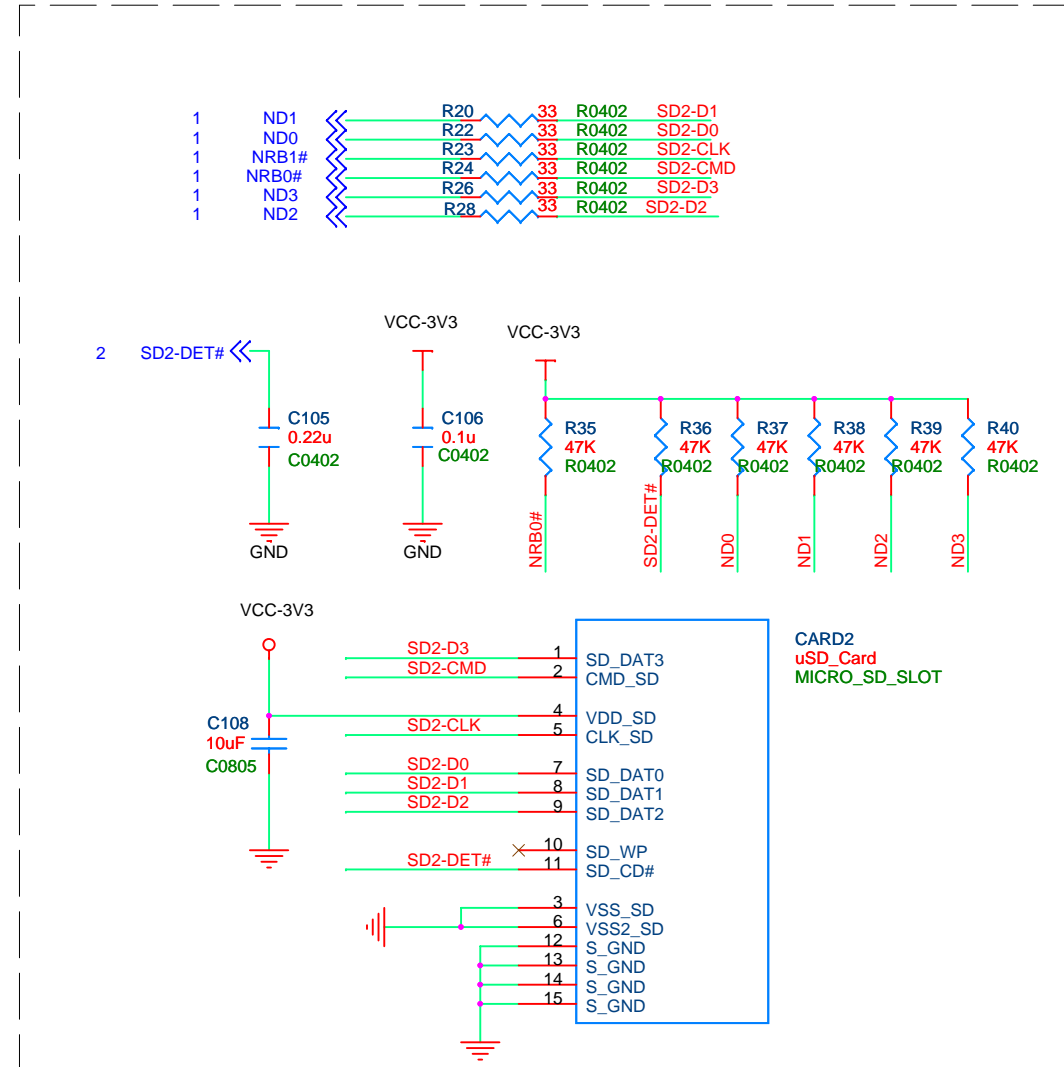

NAND flash

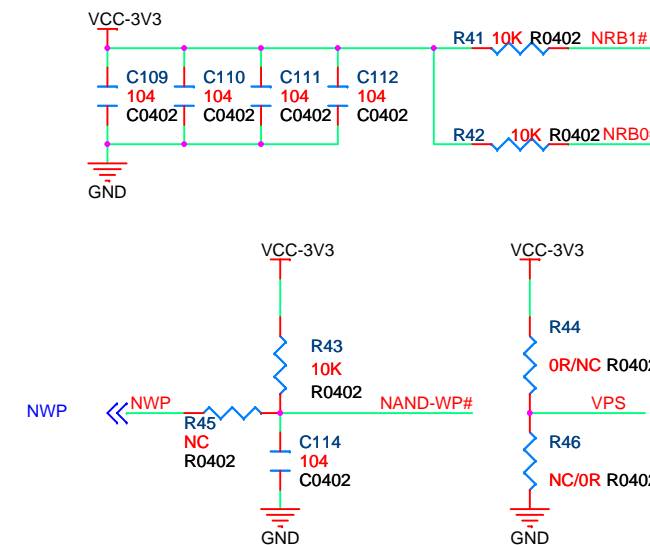
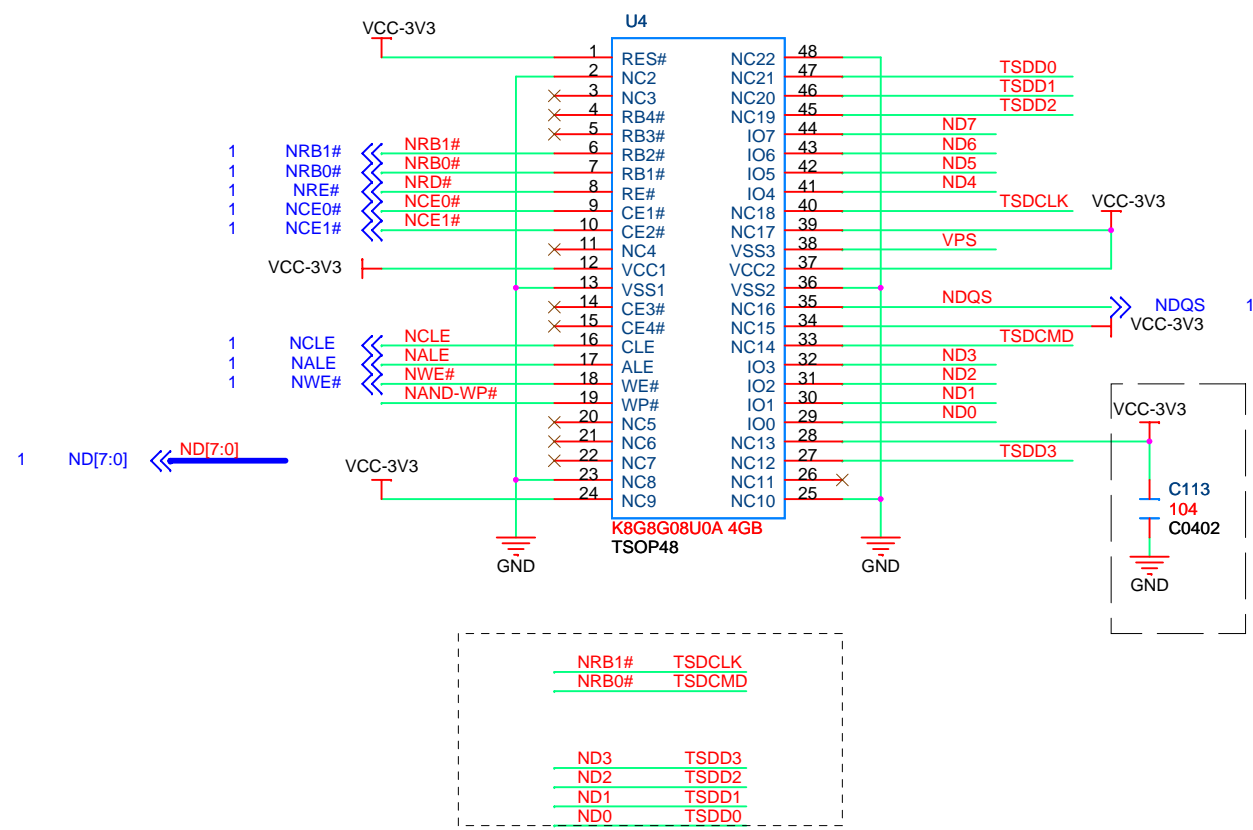

SATA

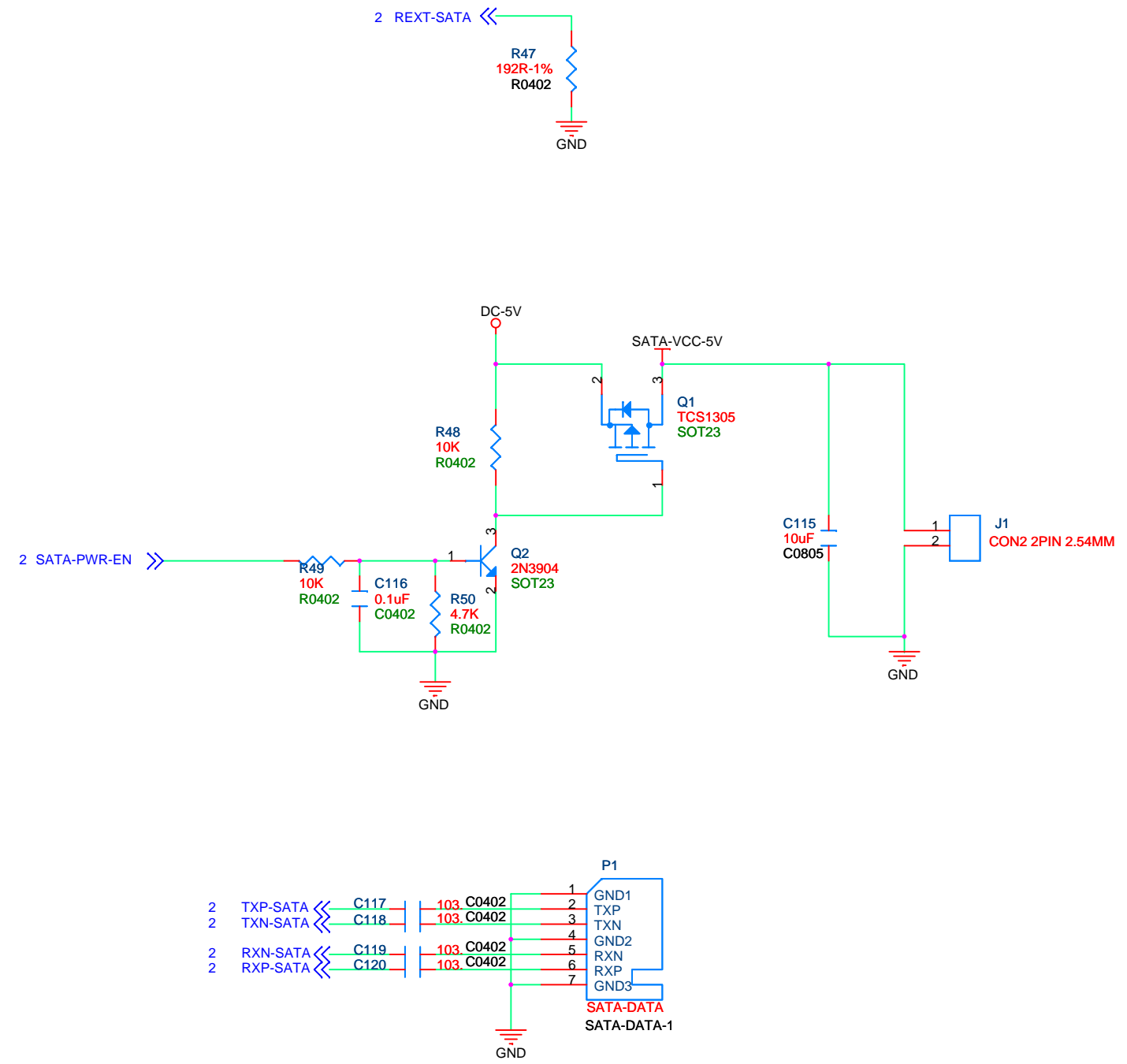

DC-IN & DC-DC

Solder option with DC-JACK, coreboard can be powered from extended board through it in other embeded system app.

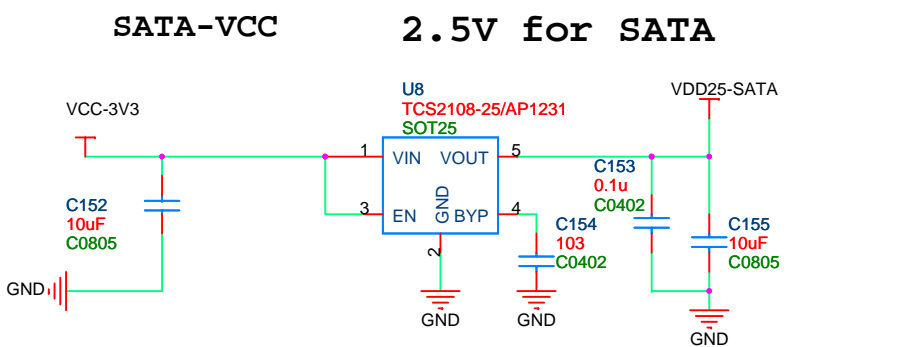
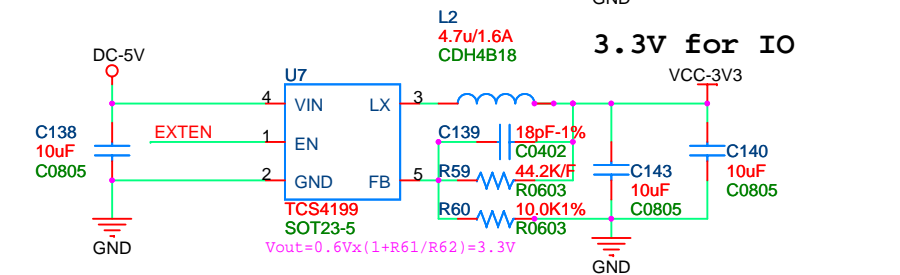
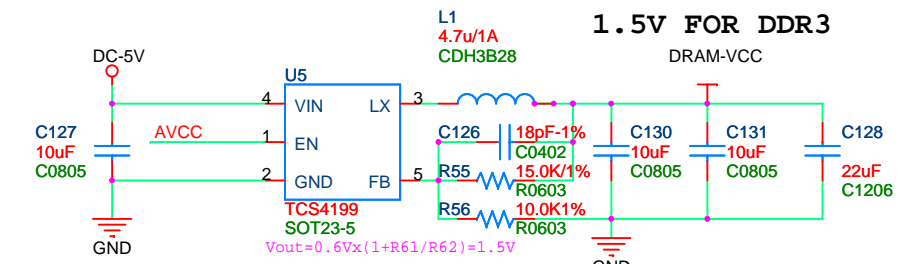
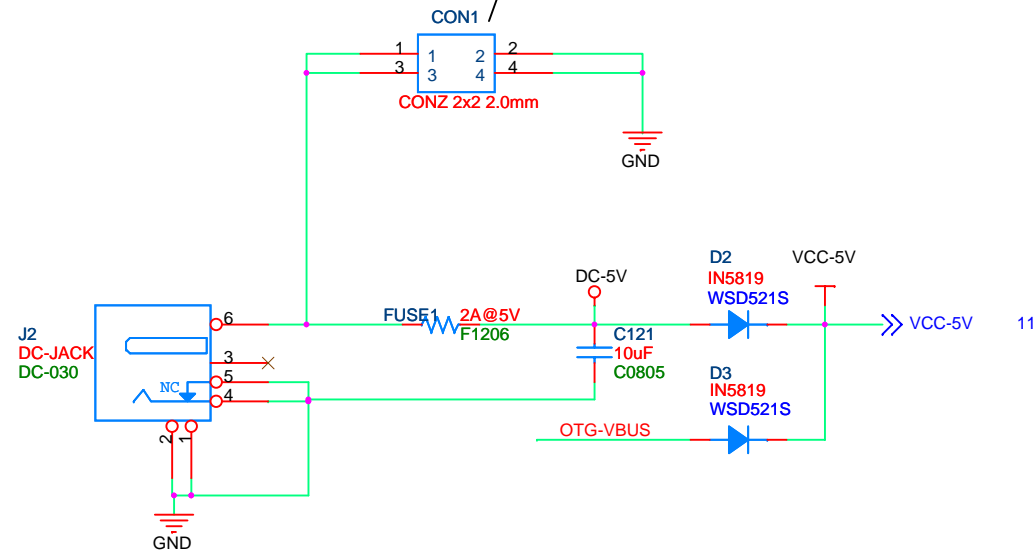

PMU

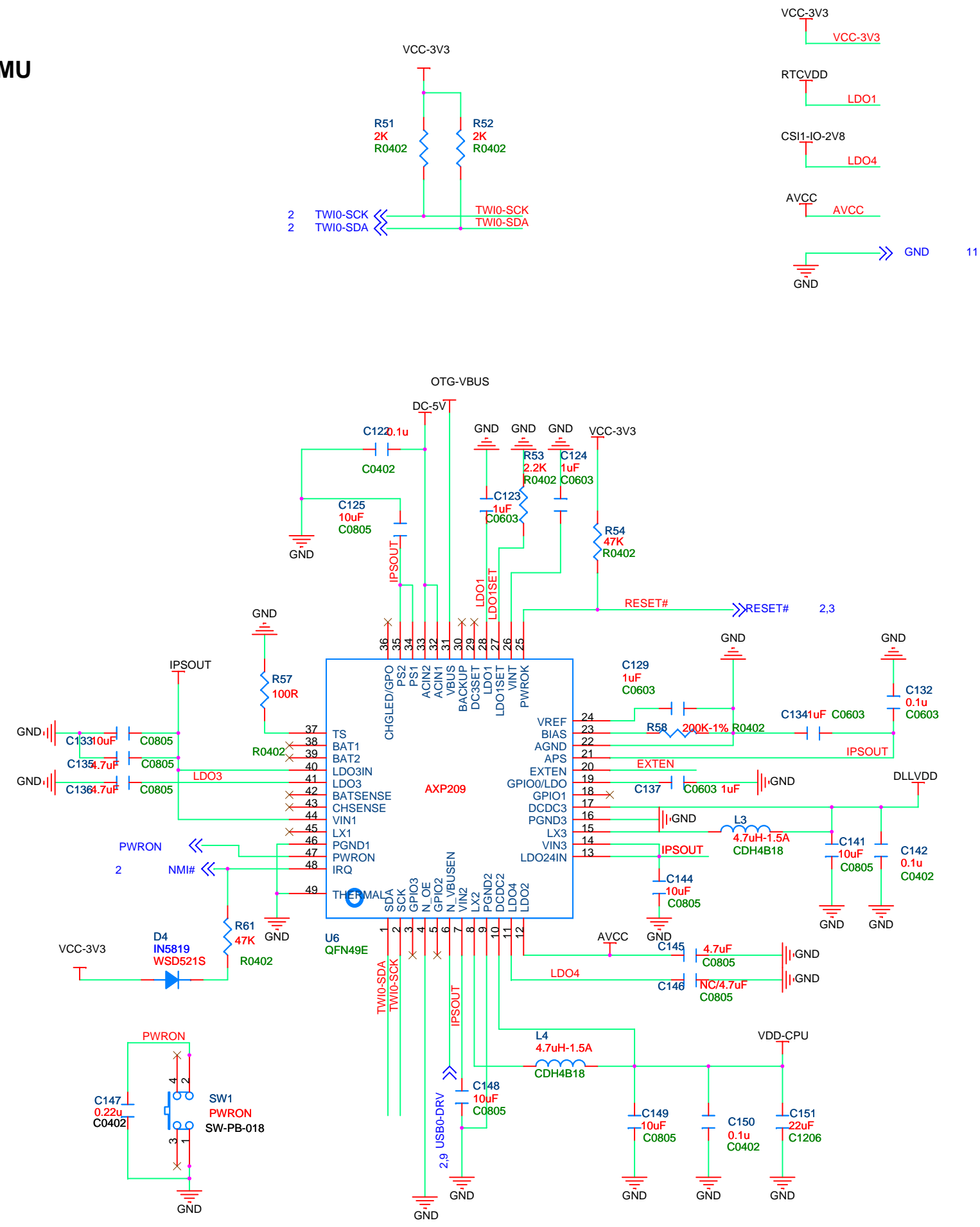

Title		
AZD-A7N-1GB Document		
Size	Number	Rev
A3	Document Number	V1.0
Date:	<Doc><Doc><Doc>	Sheet 7 of 11

HDMI

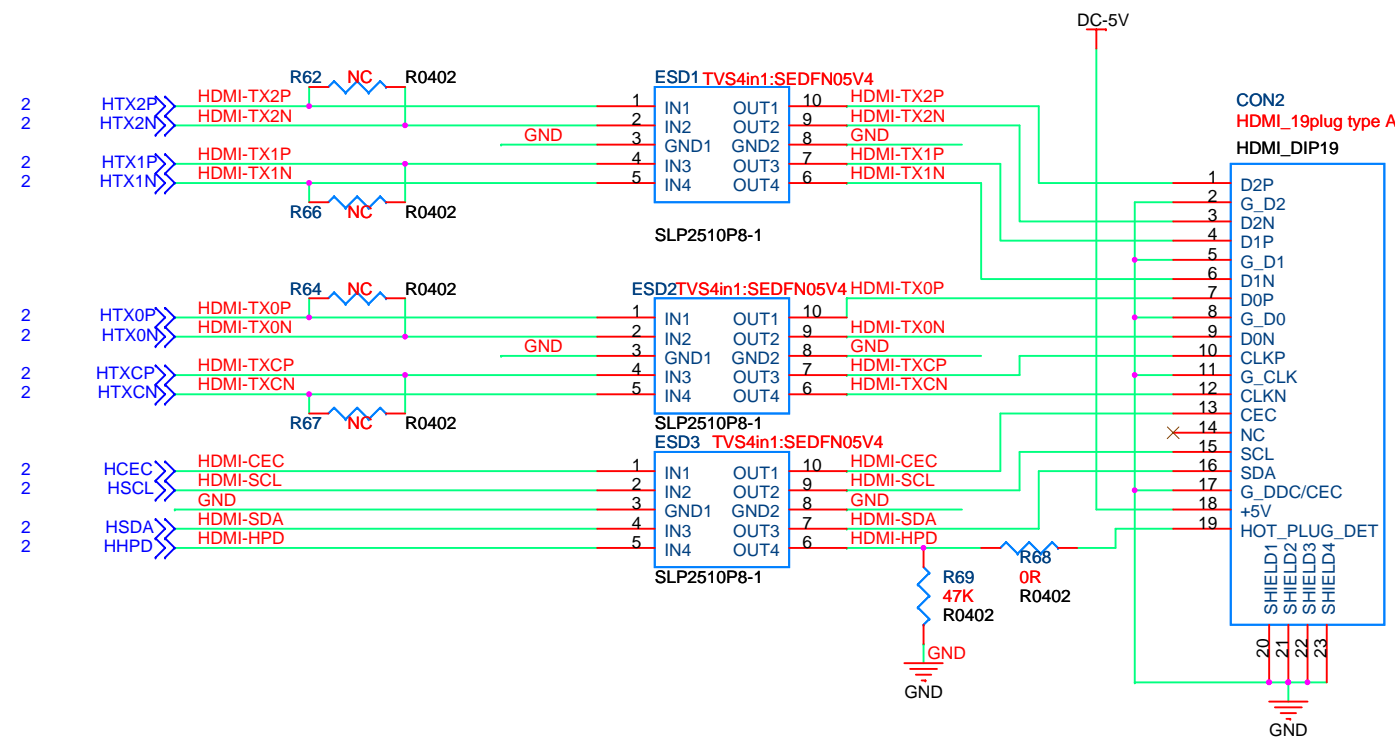

LEDs

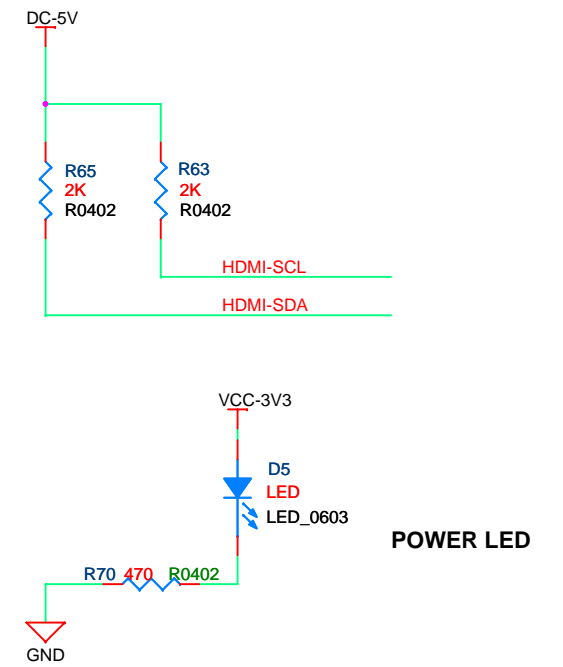

IR MODULE

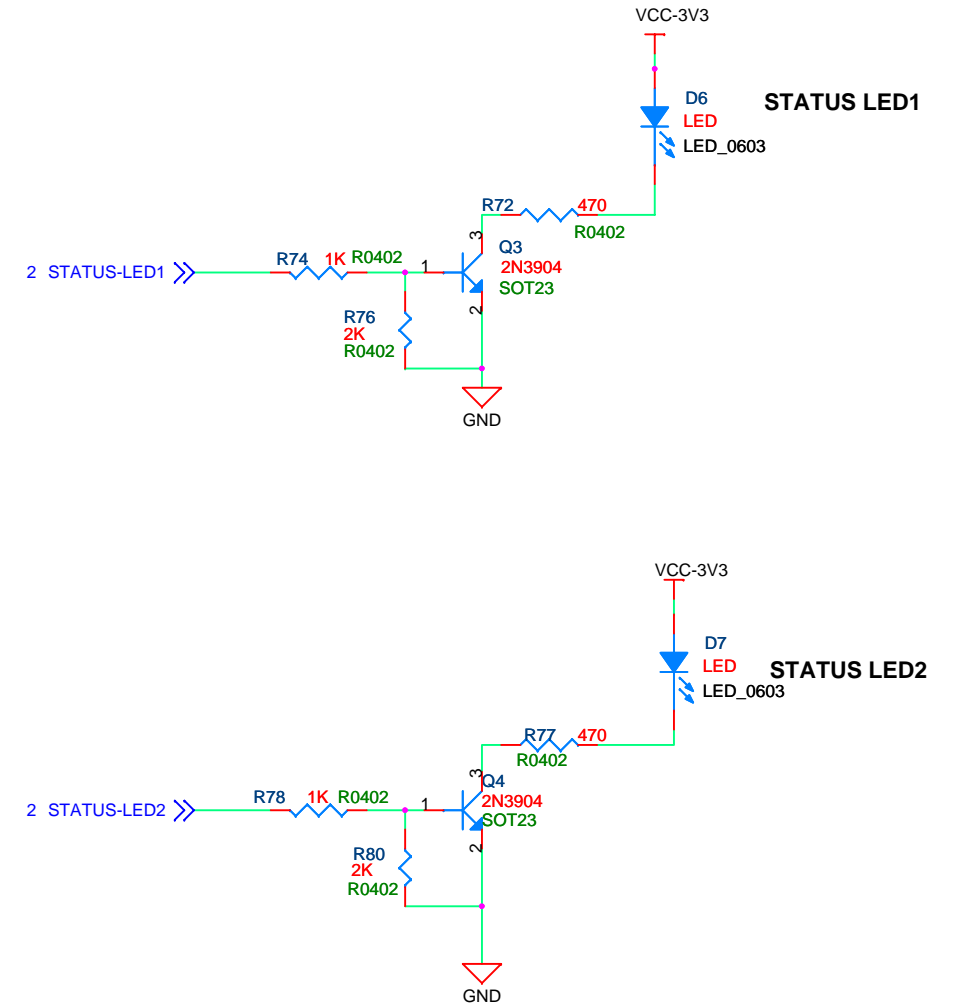
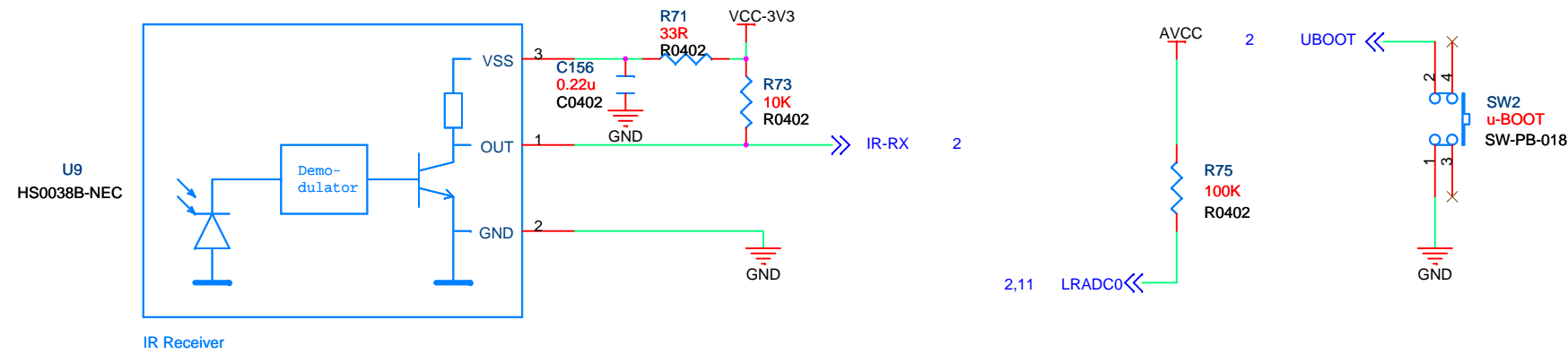

DEBUG

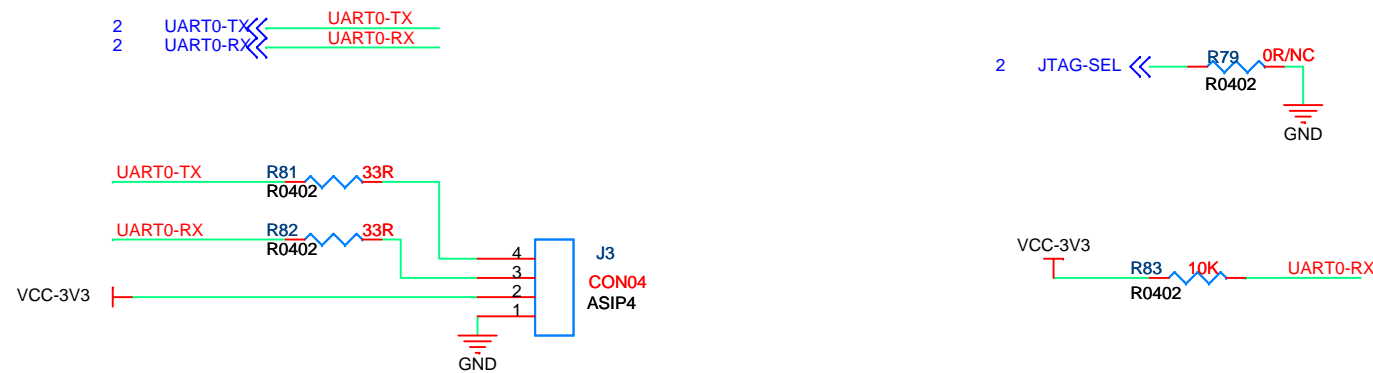

Title		
AZD-A7N-1GB Document		
Size	Number	Rev
A3	Document Number	V1.0
Date:	<Doc><Doc><Doc>	
Sheet 8 of 11		

USB HOST x 2

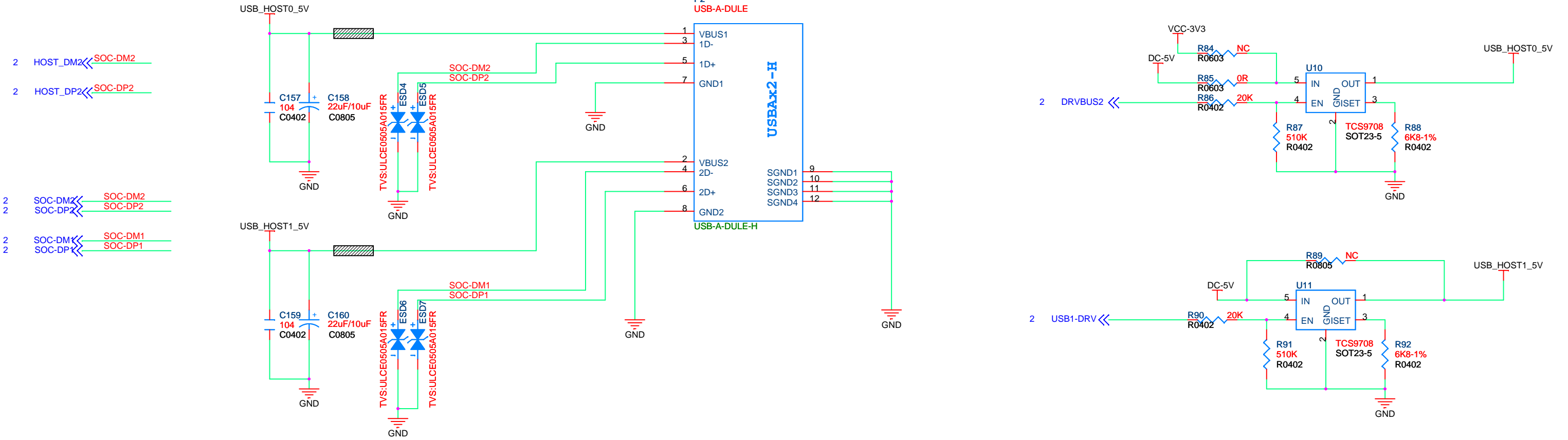

OTG

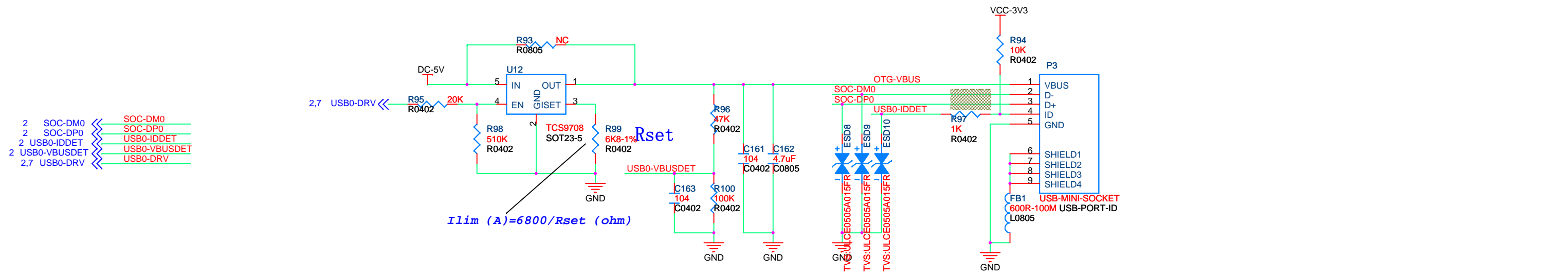

Title		
AZD-A7N-1GB Document		
Size	Number	Rev
A3	Document Number	V1.0
Date:	<Doc><Doc><Doc>	Sheet 9 of 11

EMAC

- 2 ERXD3 << ERXD3
- 2 ERXD2 << ERXD2
- 2 ERXD1 << ERXD1
- 2 ERXD0 << ERXD0
- 2 ETXD3 << ETXD3
- 2 ETXD2 << ETXD2
- 2 ETXD1 << ETXD1
- 2 ETXD0 << ETXD0
- 2 ERXCK << ERXCK
- 2 ERXERR << ERXERR
- 2 ERXDV << ERXDV
- 2 EMDIO << EMDIO
- 2 ETXEN << ETXEN
- 2 ETXCK << ETXCK
- 2 ECRS << ECRS
- 2 ECOL << ECOL

- 2 ETXERR << EPHY-RST#

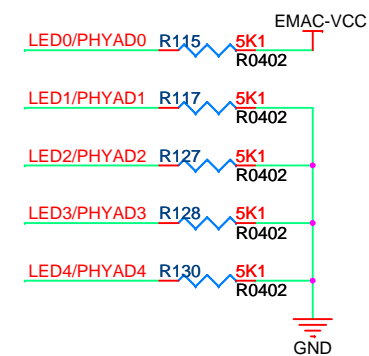
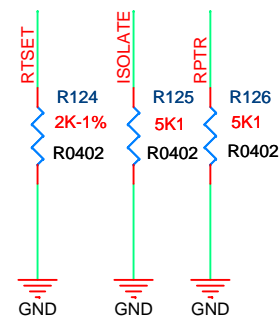
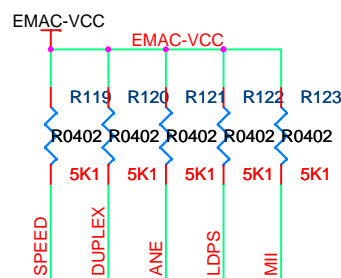
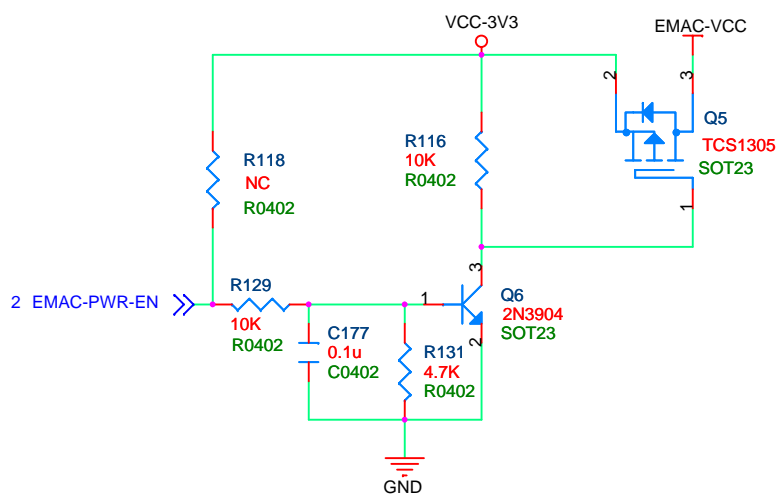
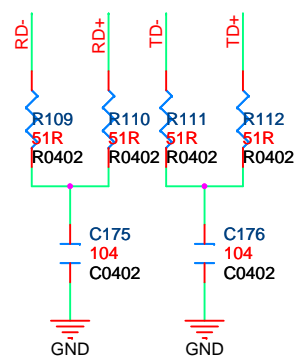
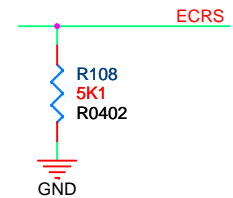
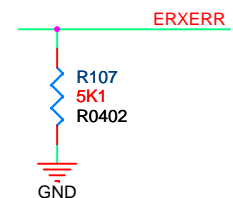
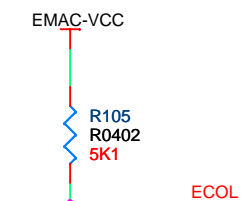
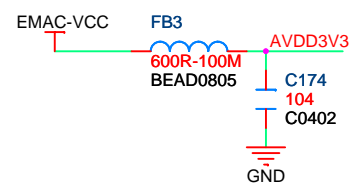
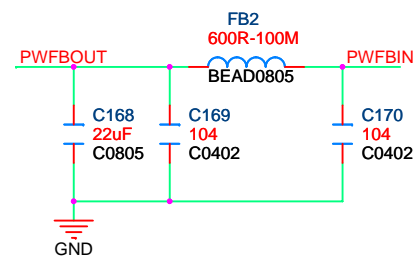
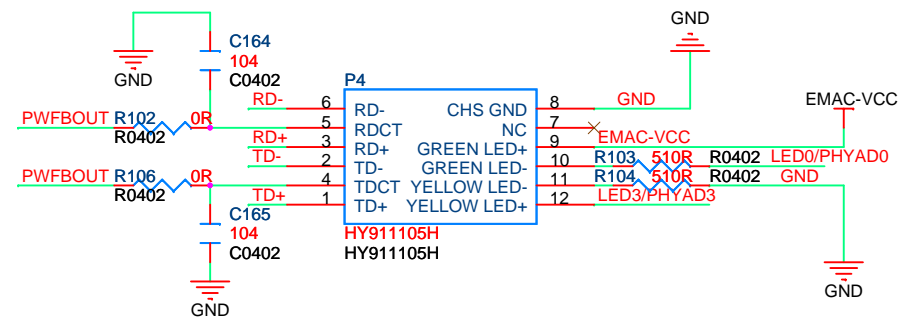
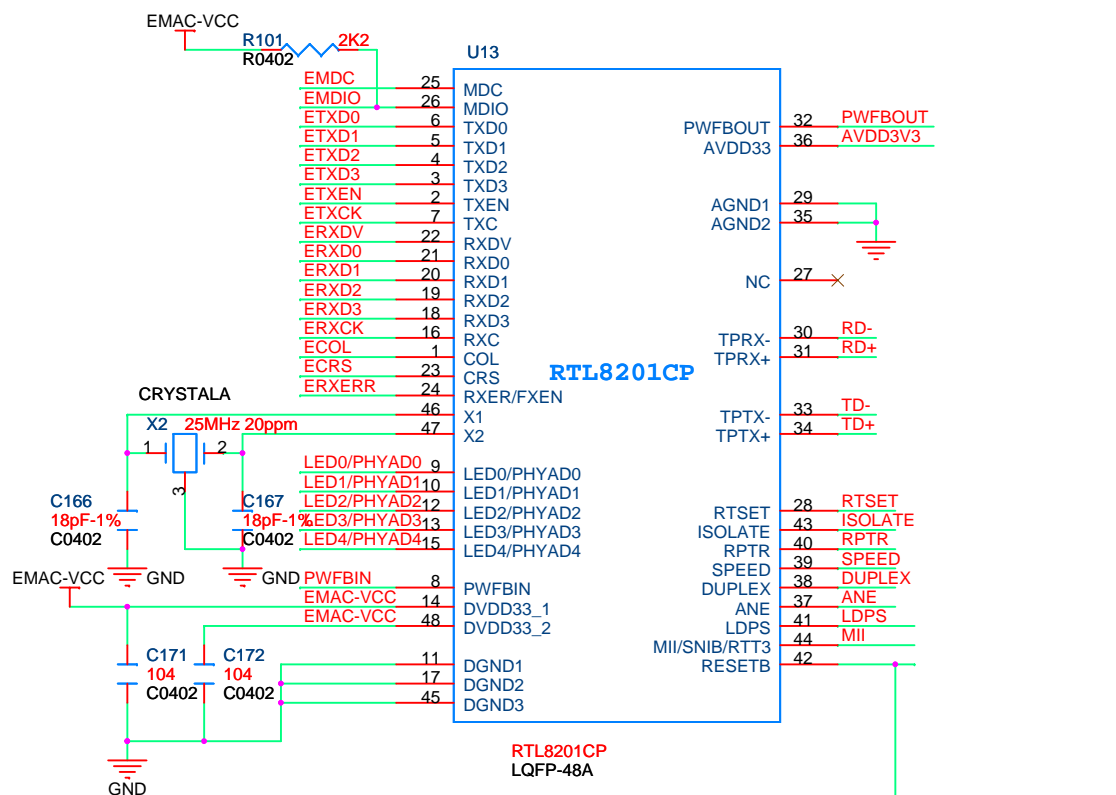

Title		
AZD-A7N-1GB Document		
Size	Number	Rev
A3	Document Number	V1.0
Date:	Sheet	10 of 11

Extention interface

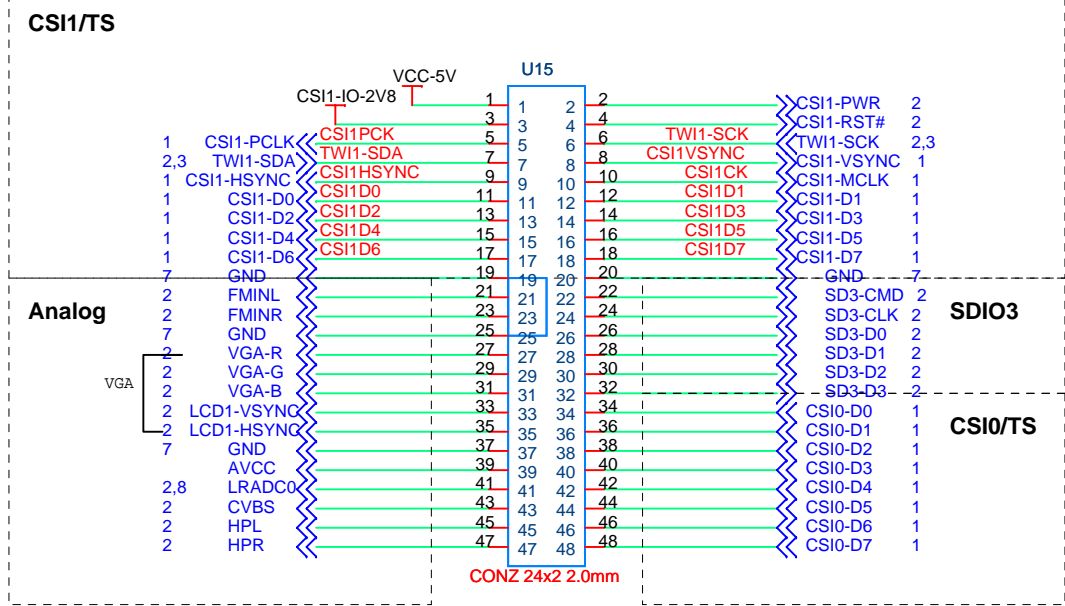
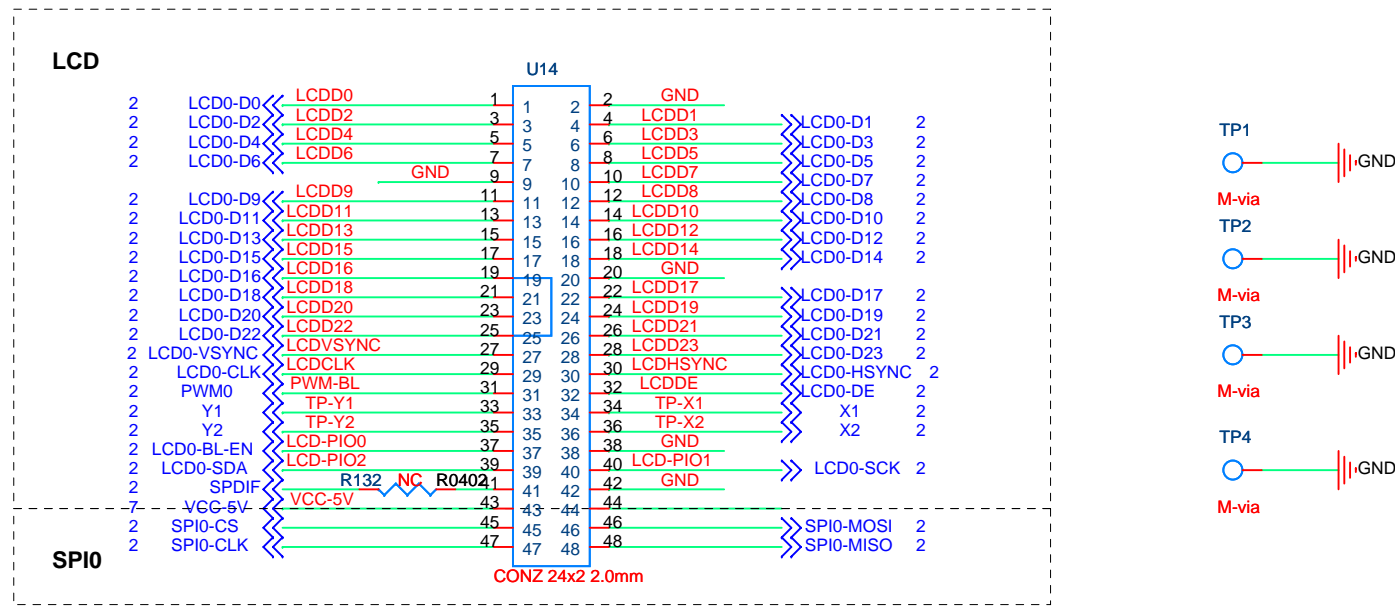

Line-In

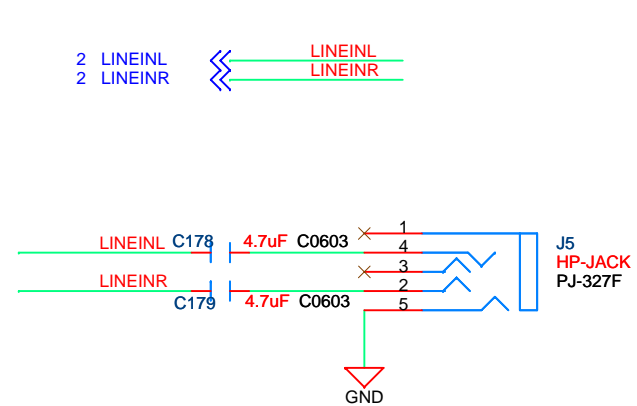

Head Phone & Speaker

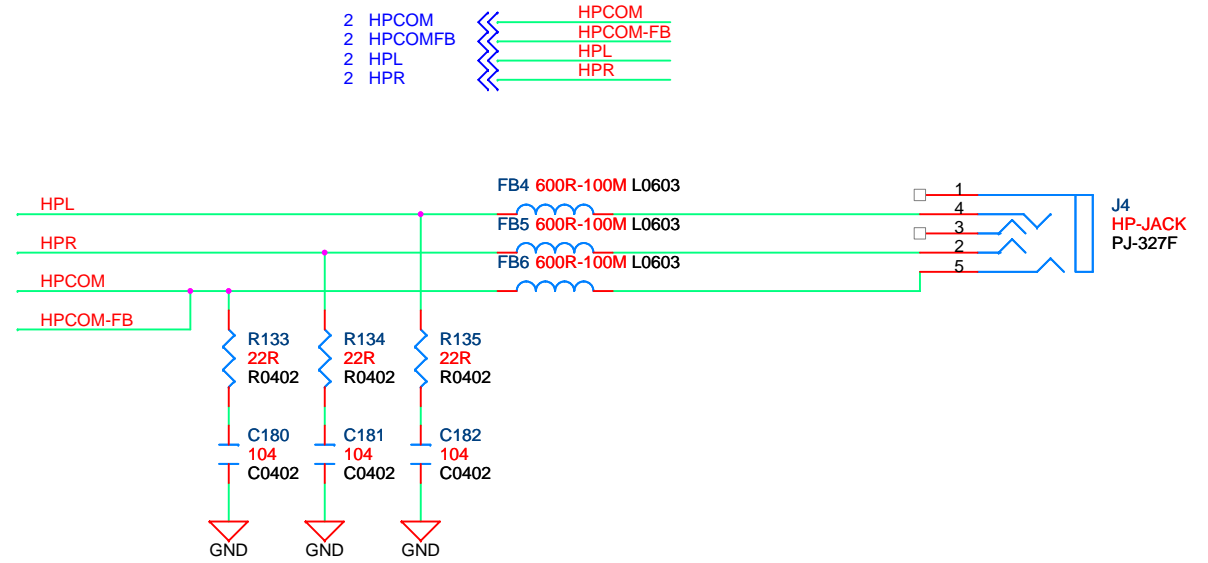

AZD-A7N-1GB 96 Extended Pins Definition

U14			
PIN	DEF	PIN	DEF
48	PI13	47	PI11
46	PI12	45	PI10
44	3.3V	43	VCC-5V
42	GND	41	PB13
40	PB10	39	PB11
38	GND	37	PH7
36	XN-TP	35	YN-TP
34	XP-TP	33	YP-TP
32	PD25	31	PB2
30	PD26	29	PD24
28	PD23	27	PD27
26	PD21	25	PD22
24	PD19	23	PD20
22	PD17	21	PD18
20	GND	19	PD16
18	PD14	17	PD15
16	PD12	15	PD13
14	PD10	13	PD11
12	PD8	11	PD9
10	PD7	9	GND
8	PD5	7	PD6
6	PD3	5	PD4
4	PD1	3	PD2
2	GND	1	PD0

U15			
PIN	DEF	PIN	DEF
1	VCC-5V	2	PH15
3	CSI1-2V8	4	PH14
5	PG0	6	PB18
7	PB19	8	PG3
9	PG2	10	PG1
11	PG4	12	PG5
13	PG6	14	PG7
15	PG8	16	PG9
17	PG10	18	PG11
19	GND	20	GND
21	FMINL	22	PI4
23	FMINR	24	PI5
25	GND	26	PI6
27	VGA-R	28	PI7
29	VGA-G	30	PI8
31	VGA-B	32	PI9
33	LCD1-VSYNC	34	PE4
35	LCD1-HSYNC	36	PE5
37	GND	38	PE6
39	AVCC	40	PE7
41	LRADC0	42	PE8
43	CVBS	44	PE9
45	HPL	46	PE10
47	HPR	48	PE11

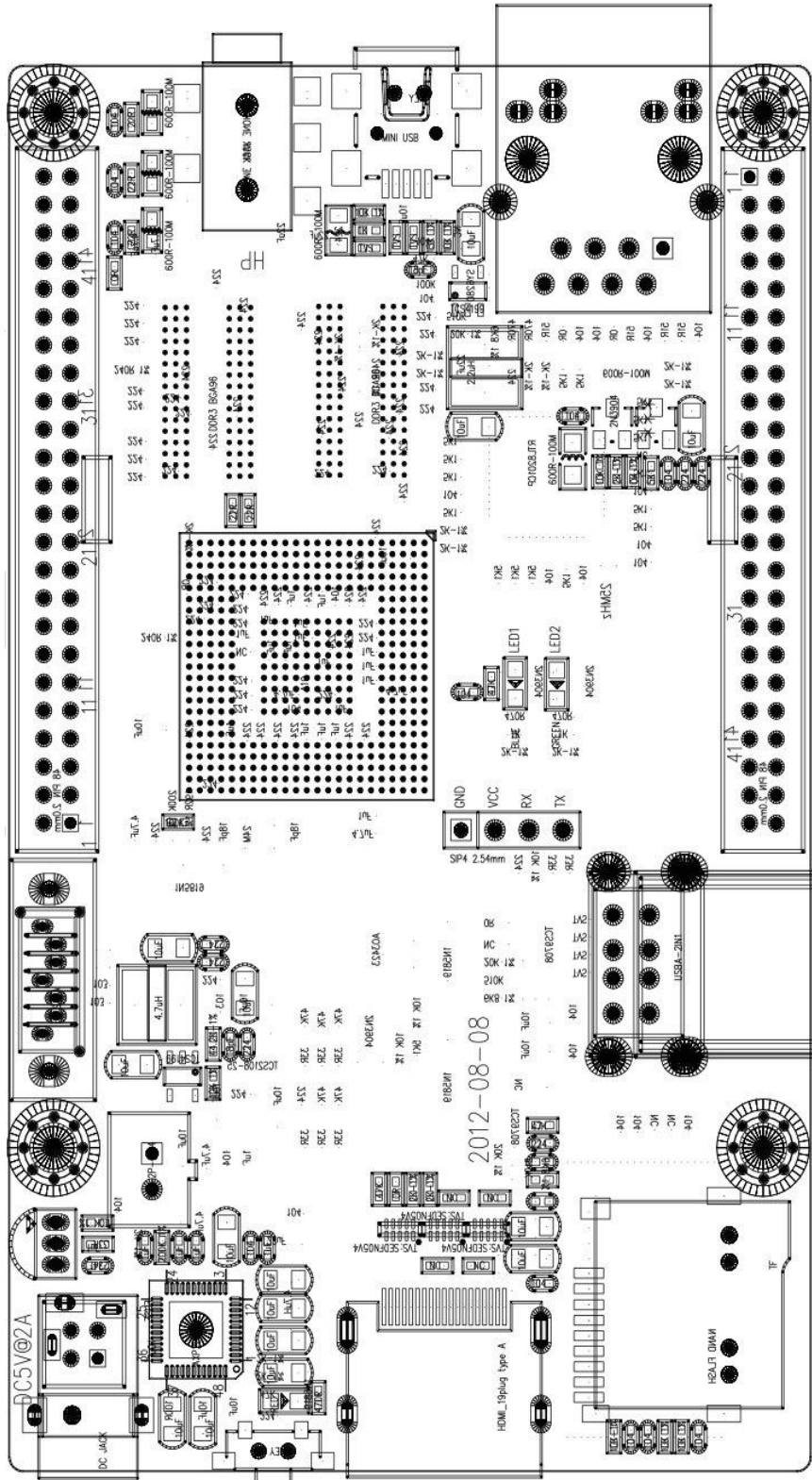

U14	Port	Multiplex Function Select					
	Multi1	Multi2	Multi3	Multi4	Multi5	Multi6	Multi7
Pin 1	PD0	LCD0_D0	LVDS0_VP0				
Pin 2	GND						
Pin 3	PD2	LCD0_D2	LVDS0_VP1				
Pin 4	PD1	LCD0_D1	LVDS0_VN0				
Pin 5	PD4	LCD0_D4	LVDS0_VP2				
Pin 6	PD3	LCD0_D3	LVDS0_VN1				
Pin 7	PD6	LCD0_D6	LVDS0_VPC				
Pin 8	PD5	LCD0_D5	LVDS0_VN2				
Pin 9	GND						
Pin 10	PD7	LCD0_D7	LVDS0_VNC				
Pin 11	PD9	LCD0_D9	LVDS0_VN3				
Pin 12	PD8	LCD0_D8	LVDS0_VP3				
Pin 13	PD11	LCD0_D11	LVDS0_VN0				
Pin 14	PD10	LCD0_D10	LVDS1_VP0				
Pin 15	PD13	LCD0_D13	LVDS1_VN1				
Pin 16	PD12	LCD0_D12	LVDS1_VP1				
Pin 17	PD15	LCD0_D15	LVDS1_VN2				
Pin 18	PD14	LCD0_D14	LVDS1_VP2				
Pin 19	PD16	LCD0_D16	LVDS1_VPC				
Pin 20	GND						
Pin 21	PD18	LCD0_D18	LVDS1_VP3				
Pin 22	PD17	LCD0_D17	LVDS1_VNC				
Pin 23	PD20	LCD0_D20	CS11_MCLK				
Pin 24	PD19	LCD0_D19	LVDS1_VN3				
Pin 25	PD22	LCD0_D22	SMC_VPPPP				
Pin 26	PD21	LCD0_D21	SMC_VPPEN				
Pin 27	PD27	LCD0_VSYNC	SMC_SDA				
Pin 28	PD23	LCD0_D23	SMC_DET				
Pin 29	PD24	LCD0_CLK	SMC_VCCEN				
Pin 30	PD26	LCD0_HSYNC	SMC_SLK				
Pin 31	PB2	PWM0					
Pin 32	PD25	LCD0_DE	SMC_RST				
Pin 33	YP-TP						
Pin 34	XP-TP						
Pin 35	YN-TP						
Pin 36	XN-TP						
Pin 37	PH7	LCD1_D7	ATAD3	UART5_RX		EINT7	CS11_D7
Pin 38	GND						
Pin 39	PB11	I2S_DO3					
Pin 40	PB10	I2S_DO2					
Pin 41	PB13	SPI2_CS1					

Pin 42	GND						
Pin 43	VCC-5V						
Pin 44	3.3V						
Pin 45	PI10	SPI0_CS0	UART5_TX			EINT22	
Pin 46	PI12	SPI0_MOSI	UART6_TX				
Pin 47	PI11	SPI0_CLK	UART5_RX			EINT23	
Pin 48	PI13	SPI0_MISO	UART6_RX			EINT25	

U15	Port	Multiplex Function Select					
	Multi1	Multi2	Multi3	Multi4	Multi5	Multi6	Multi7
Pin 1	VCC-5V						
Pin 2	PH15	LCD1_D15	ATAD11	KP_IN5	SMC_VPPPP	EINT15	CSI1_D15
Pin 3	CSI1-2V8						
Pin 4	PH14	LCD1_D14	ATAD10	KP_IN4	SMC_VPPEN	EINT14	CSI1_D14
Pin 5	PG0	TS1_CLK	CSI1_PCLK	SDC1_CMD			
Pin 6	PB18	TWI1_SCK					
Pin 7	PB19	TWI1_SDA					
Pin 8	PG3	TS1_DVLD	CSI1_VSYNC	SDC1_D1			
Pin 9	PG2	TS1_SYNC	CSI1_HSYNC	SDC1_D0			
Pin 10	PG1	TS1_ERR	CSI1_MLCK	SDC1_CLK			
Pin 11	PG4	TS1_D0	CSI1_D0	SDC1_D2	CSI0_D8		
Pin 12	PG5	TS1_D1	CSI1_D1	SDC1_D3	CSI0_D9		
Pin 13	PG6	TS1_D2	CSI1_D2	UART3_TX	CSI0_D10		
Pin 14	PG7	TS1_D3	CSI1_D3	UART3_RX	CSI0_D11		
Pin 15	PG8	TS1_D4	CSI1_D4	UART3_RT S	CSI0_D12		
Pin 16	PG9	TS1_D5	CSI1_D5	UART3_CT S	CSI0_D13		
Pin 17	PG10	TS1_D6	CSI1_D6	UART4_TX	CSI0_D14		
Pin 18	PG11	TS1_D7	CSI1_D7	UART4_RX	CSI0_D15		
Pin 19	GND						
Pin 20	GND						
Pin 21	FMINL						
Pin 22	PI4	SDC3_CMD					
Pin 23	FMINR						
Pin 24	PI5	SDC3_CLK					
Pin 25	GND						
Pin 26	PI6	SDC3_D0					
Pin 27	VGA-R						
Pin 28	PI7	SDC3_D1					
Pin 29	VGA-G						
Pin 30	PI8	SDC3_D2					
Pin 31	VGA-B						

Pin 32	PI9	SDC3_D3					
Pin 33	PH27	LCD1-VSY NC					
Pin 34	PE4	TS0_D0	CSI0_D0				
Pin 35	PH26	LCD1-HSY NC					
Pin 36	PE5	TS0_D1	CSI0_D1				
Pin 37	GND						
Pin 38	PE6	TS0_D2	CSI0_D2				
Pin 39	AVCC						
Pin 40	PE7	TS0_D3	CSI0_D3				
Pin 41	LRADC0						
Pin 42	PE8	TS0_D4	CSI0_D4				
Pin 43	CVBS						
Pin 44	PE9	TS0_D5	CSI0_D5				
Pin 45	HPL						
Pin 46	PE10	TS0_D6	CSI0_D6				
Pin 47	HPR						
Pin 48	PE11	TS0_D7	CSI0_D7				

AZD-A7N-1GB Simple Customization For Core-Board Application

AZD-A7N-1GB is mainly targeted at mini-pc development board, but also consider some of core-board applications. What's well known is that 96 extended pins with lots of applied circuit interfaces. Here, I would like to introduce some tips in core-board applications.

- 1、 You can power the AZD-A7N-1GB via 4-pin 2.0mm pitch dual in-line connector from base-board.
- 2、 The IR receiver module can be extended to anywhere you want via 3-pin 2.0mm pitch single in-line connector.
- 3、 The USB HOST can be extended to anywhere you want via 8-pin 2.0mm pitch dual in-line connector.
- 4、 All the DIP components are optional if you want to order core-board version of CB0909, such as DC Jack, IR module, SATA5V, SATA DATA connector, NIC, USB A connector, 32768Hz crystal, 25MHz crystal, 4 pin 2.54mm pinheader for UART.

Below is some photos for pins and nets name list maybe useful.

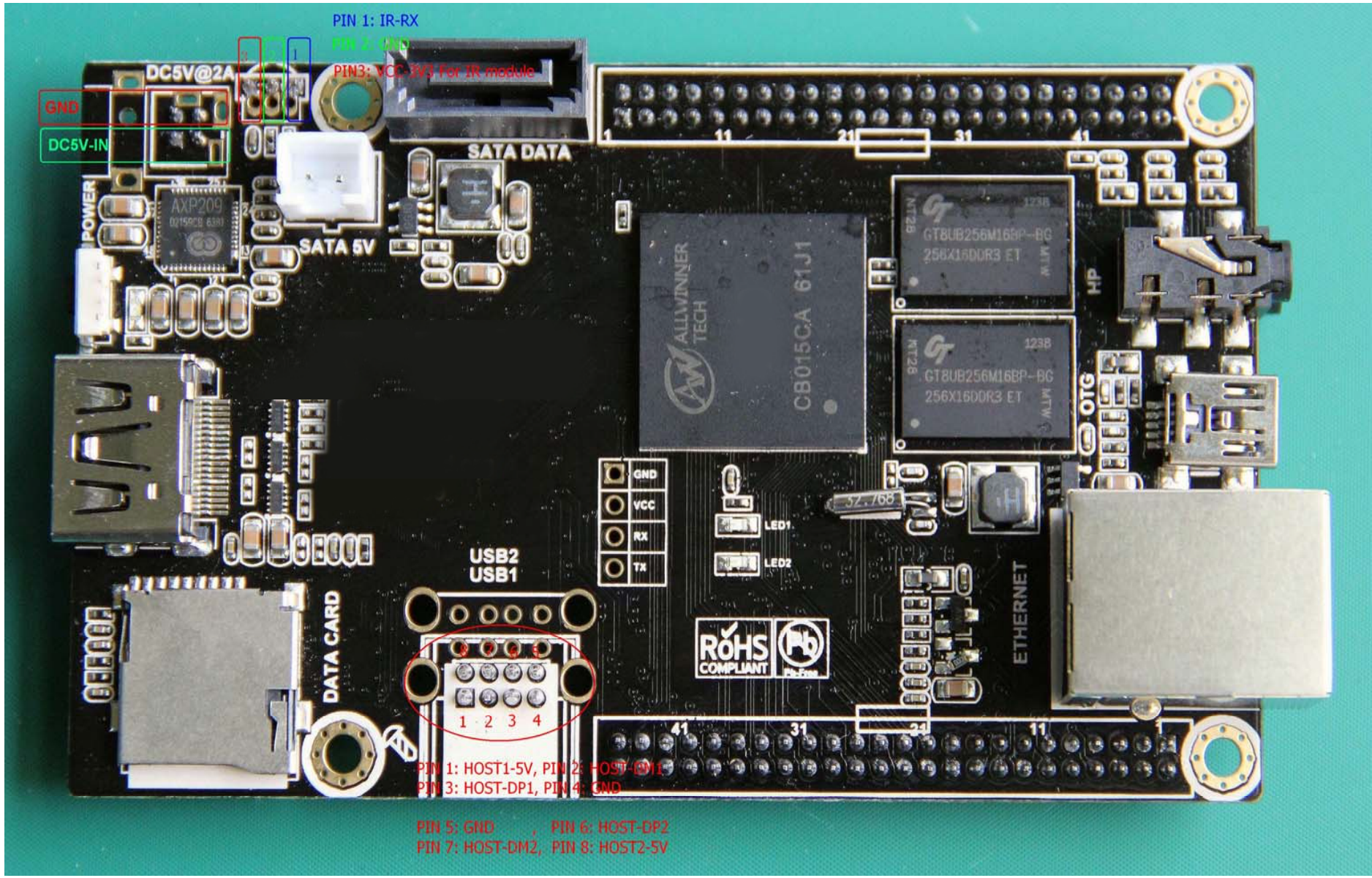

PIN 1: IR-RX

PIN 2: GND

PIN3: VCC 3V3 For IR module

GND

DC5V-IN

USB2
USB1

1 2 3 4

PIN 1: HOST1-5V, PIN 2: HOST-GND1
PIN 3: HOST-DP1, PIN 4: GND

PIN 5: GND, PIN 6: HOST-DP2
PIN 7: HOST-DM2, PIN 8: HOST2-5V

