

AZ DISPLAYS

SPECIFICATIONS FOR LIQUID CRYSTAL DISPLAY

CUSTOMER APPROVAL			
※ PART NO. : <u>AGM2464BD-FLW-GBW (AZ DISPLAYS) VER 1.0</u>			
APPROVAL		COMPANY CHOP	
CUSTOMER COMMENTS			

AZ DISPLAYS ENGINEERING APPROVAL		
DESIGNED BY	CHECKED BY	APPROVED BY
WJQ	LJF	GZH

REVISION RECORD

REVISION	REVISION DATE	PAGE	CONTENTS
VER1.0	2016-08-10		FIRST ISSUE

※ **CONTENTS**

- 1.0 GENERAL SPECS
- 2.0 ABSOLUTE MAXIMUM RATINGS
- 3.0 ELECTRICAL CHARACTERISTICS
- 4.0 OPTICAL CHARACTERISTICS
- 5.0 BLOCK DIAGRAM
- 6.0 PIN ASSIGNMENT
- 7.0 POWER SUPPLY
- 8.0 TIMING CHARACTERISTICS
- 9.0 MECHANICAL DIAGRAM
- 10.0 RELIABILITY TEST
- 11.0 DISPLAY INSTRUCTION TABLE
- 12.0 APPEARANCE CRITERIA
- 13.0 PRECAUTION FOR USING LCM

1.0 GENERAL SPECS

1. Display Format	240*64 DOTS
2. Power Supply LCM	5.0V(Single power supply with integrated DC-DC,adjustable Vop)
3. Overall Module Size	180.0mm(W) x65.0mm(H) x max 15.0mm(D)
4. Viewing Area(W*H)	133.0mm(W) x 39.0mm(H)
5. Dot Size (W*H)	0.49mm(W) x 0.49mm(H)
6. Dot Pitch (W*H)	0.53mm(W) x 0.53mm(H)
7. Viewing Direction	6:00 O'Clock
8. Driving Method	1/64 Duty,1/9 Bias
9. Controller IC	RA6963
10. Display Mode	STN(Gray) /Positive /Transflective
11. Backlight Options	White LED/Side
12. Operating temperature	-20°C ~ 70°C
13. Storage temperature	-30°C ~ 80°C
14. RoHS	RoHS compliant

2.0 ABSOLUTE MAXIMUM RATINGS

Item	Symbol	Min	Typ	Max	Unit
Operating temperature	Top	-20	--	70	°C
Storage temperature	Tst	-30	--	80	°C
Input voltage	Vin	Vss-0.3	--	Vdd+0.3	V
Supply voltage for logic	Vdd- Vss	-0.3	-	7.0	V
Supply voltage for LCD driving	Vdd- V0	6		28	V

3.0 ELECTRICAL CHARACTERISTICS

3.1 Electrical Characteristics Of LCM

Item	Symbol	Condition	Min	Typ	Max	Unit
Power Supply Voltage	Vdd	25°C	4.8	5.0	5.2	V
Power Supply Current	Idd	Vdd=5.0V	--	--	25	mA
Input voltage (high)	Vih	Pins:(/WR, /RD, /CE, C/D, /RESET,DB0-DB7,FS) VDD=5V	VDD-2.2	--	Vdd	V
Input voltage (low)	Vil		0	--	0.8	V
Recommended Driving Voltage	LC Vdd -V0	-20°C	--	--	--	V
		25°C	--	11.5	--	
		70°C	--	--	--	

3.2 The Characteristics Of LED Backlight

3.2.1 Electrical-Optical Characteristics Of LED Backlight (Ta=25°C)

Item	Symbol	Condition	Min	Typ	Max	Unit
Forward Voltage ⁽¹⁾	Vf	If=90mA	2.9	3.1	3.3	V
Reverse Voltage	Vr	-	--	--	5	V
Luminance ⁽²⁾	Lv	If=90mA	175	--	--	cd/m ²
Uniformity ⁽³⁾	Δ	(Lvmin/Lvmax)%	70%	--	--	-
Peak wave length	λ p	-	--	--	--	nm
Chroma coordinate	x	If=90mA	0.25	--	0.29	um
	y	If=90mA	0.26	--	0.30	um
Lifetime ⁽⁴⁾	-	If=90mA	-	20000	-	Hours

NOTE:

(1) Forward voltage means voltage applied directly to the LED, please refer to the backlight diagram.

(2) The luminance is the average value of 5 points, The measurement instrument is BM-7 luminance colorimeter. The diameter of aperture is Φ5mm

(3) Luminance means the backlight brightness without LCD.

(4) Backlight lifetime means luminance value larger than half of the original after 20000 hours' continuous working.

(5) Please apply the backlight current as the table recommend. If LCM surface luminance is acceptable, please apply the driving current as lower as possible. Any time, do not apply the driving current higher than 100mA.

3.2.2 Backlight Control Circuit

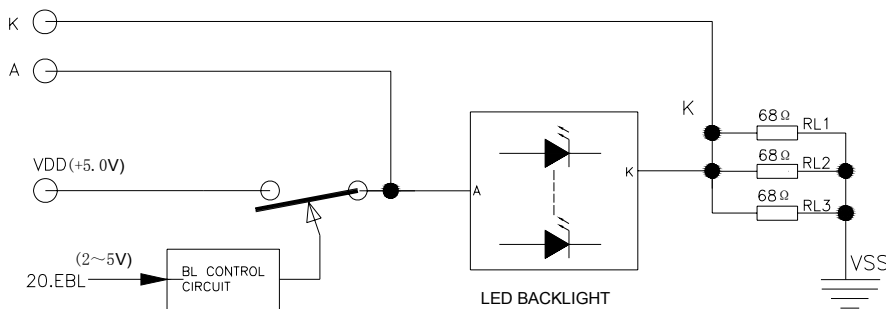

3.2.3 The Backlight diagram (LED 8*1=8 dices)

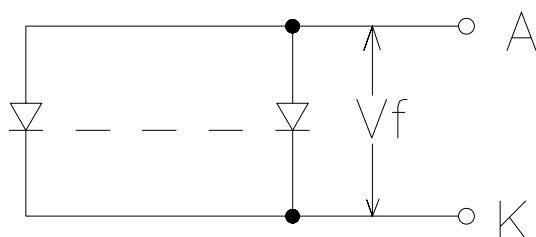

3.2.4 LED Typical Electro-Optical Characteristics Curve (for single led)

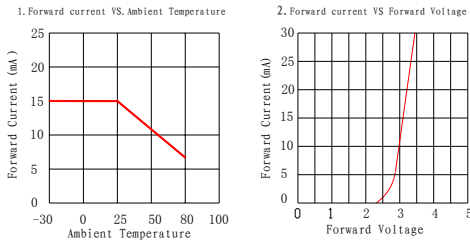

4.0 OPTICAL CHARACTERISTICS (Ta=25°C)

Item	Symbol	Condition	Min	Typ	Max	Unit
Viewing angle (Left - right)	θ_2	$Cr \geq 2.0$	-35	-	35	deg
Viewing angle (Up-down)	θ_1	$Cr \geq 2.0$	-25	-	35	deg
Contrast Ratio	Cr	$\theta_1=0^\circ, \theta_2=0^\circ$	-	5	-	
Response time (rise)	Tr	$\theta_1=0^\circ, \theta_2=0^\circ$	-	180	300	ms
Response time (fall)	Tf	$\theta_1=0^\circ, \theta_2=0^\circ$	-	150	250	ms

(1). Definition of Optical Response Time

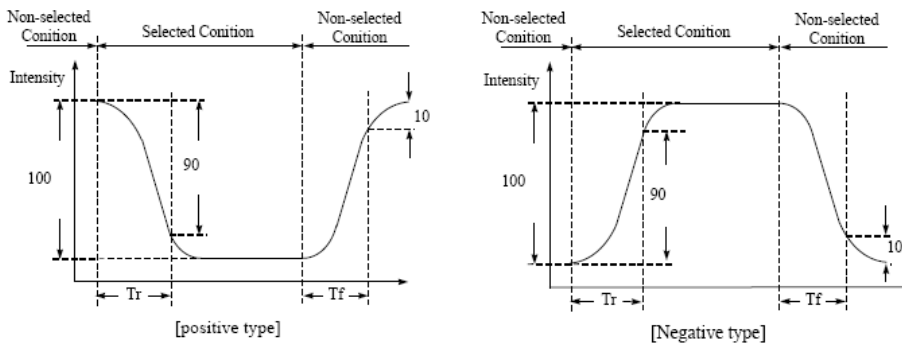

(2). Definition of Contrast Ratio

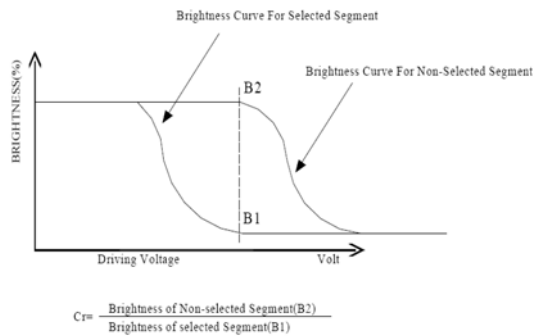

(3). Definition of Viewing Angle θ_2 and θ_1

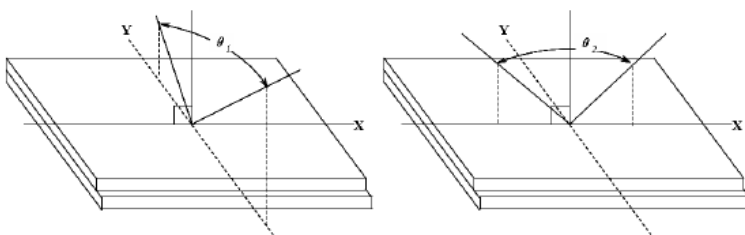

5.0 BLOCK DIAGRAM

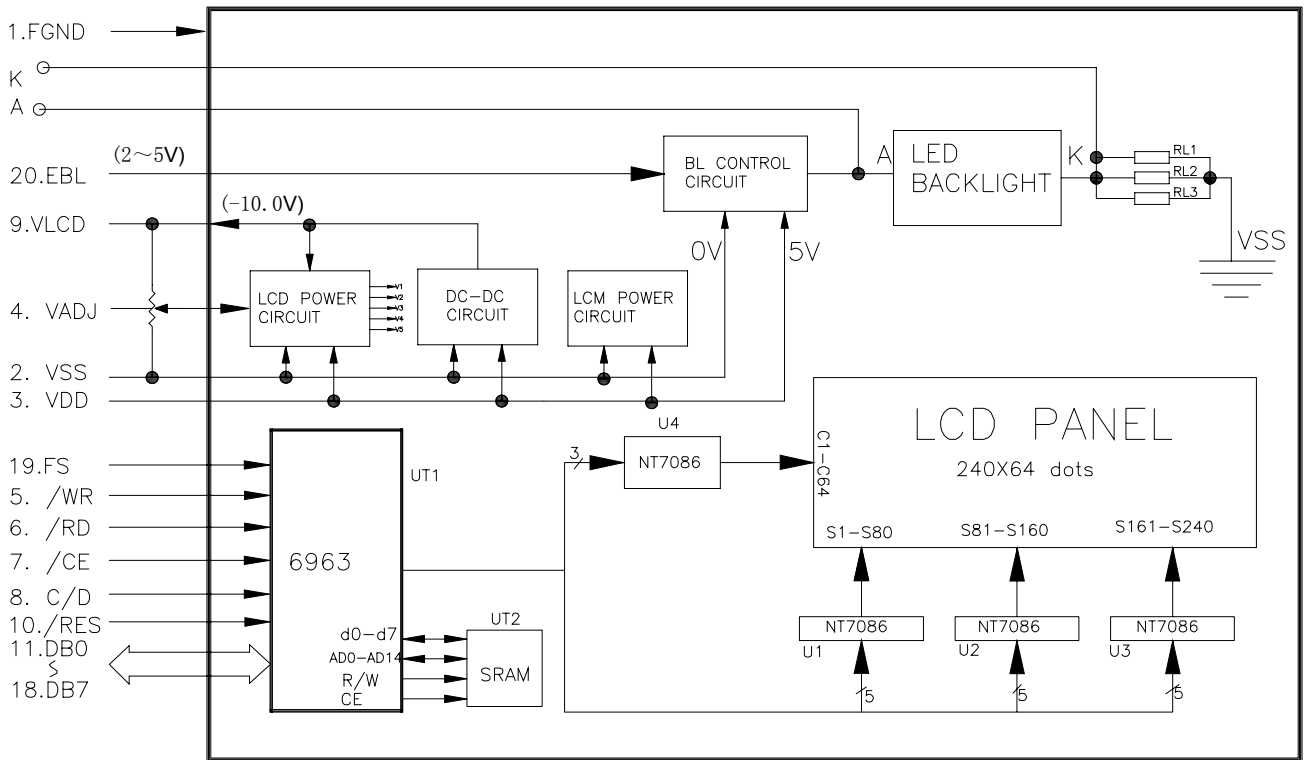

6.0 PIN ASSIGNMENT

Pin No.	Symbol	Function	Level
1	FGND	Frame Ground	-
2	Vss	Ground	-
3	Vdd	+5V	-
4	VADJ	LCD contrast adjust	-
5	/WR	Write Data	H/L
6	/RD	Read Data	H/L
7	/CE	Chip Enable	H, H→L
8	C/D	Command/Data	H/L
9	VLCD	Power supply for LCD driving	-10.0V, internal DC-DC
10	/RES	Reset	L
11	DB0	Data bit 0	H/L
12	DB1	Data bit 1	H/L
13	DB2	Data bit 2	H/L
14	DB3	Data bit 3	H/L
15	DB4	Data bit 4	H/L
16	DB5	Data bit 5	H/L
17	DB6	Data bit 6	H/L
18	DB7	Data bit 7	H/L
19	FS	Font select	Font: H:6*8; L:8*8-
20	EBL	BACKLIGHT ENABLE	NA(2V~5V)
A	LED+	Power Supply for LED+	+3.1v
K	LED-	Power Supply for LED-	0V

7.0 POWER SUPPLY

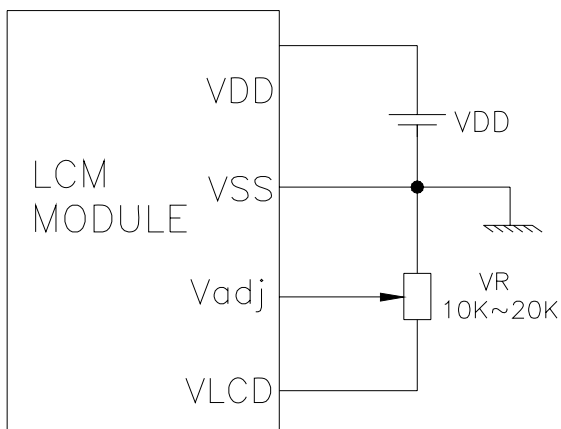

8.0 TIMING CHARACTERISTICS

(1) External RAM Read mode

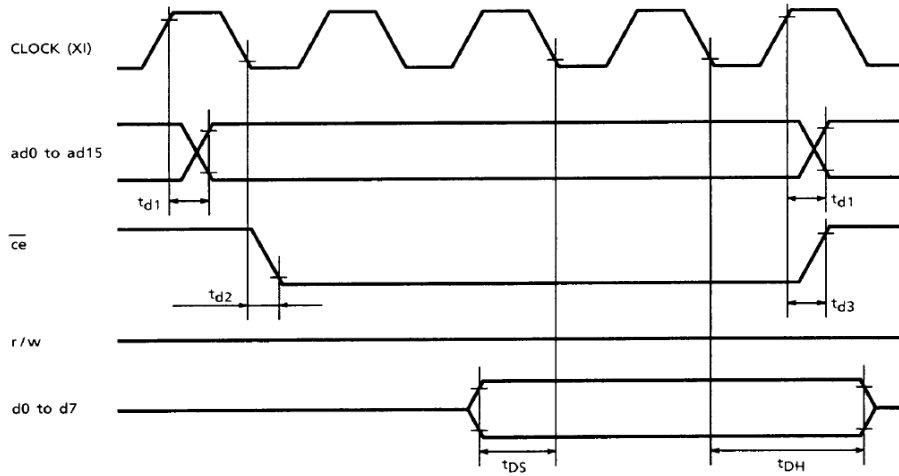

(2) External RAM Write mode

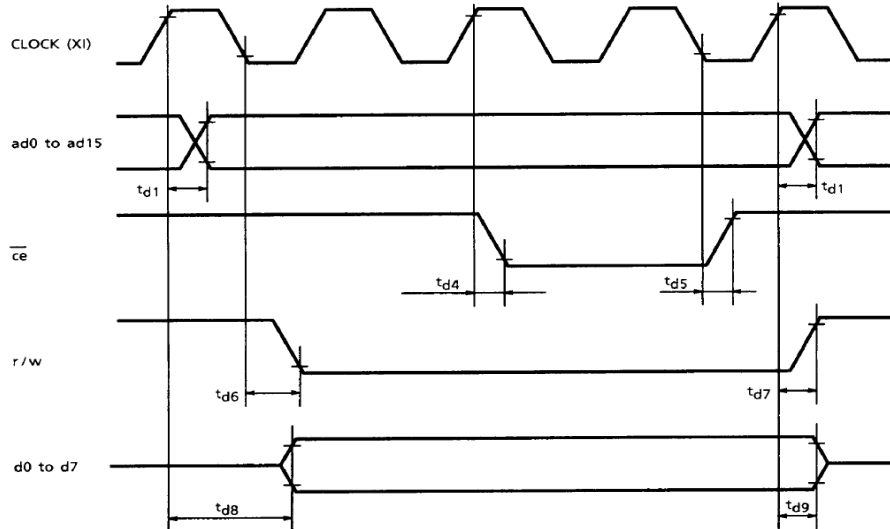

TEST CONDITIONS (Unless otherwise noted, $V_{DD} = 5.0V \pm 10\%$, $V_{SS} = 0V$, $T_a = -20$ to $70^\circ C$)

ITEM	SYMBOL	TEST CONDITIONS	MIN	MAX	UNIT
Address Delay Time	t_{d1}	—	—	250	ns
\overline{ce} Fall Delay Time (Read)	t_{d2}	—	—	180	ns
\overline{ce} Rise Delay Time (Read)	t_{d3}	—	—	180	ns
Data Set-up Time	t_{DS}	—	0	—	ns
Data Hold Time	t_{DH}	—	30	—	ns
\overline{ce} Fall Delay Time (Write)	t_{d4}	—	—	200	ns
\overline{ce} Rise Delay Time (Write)	t_{d5}	—	—	200	ns
r/w Fall Delay Time	t_{d6}	—	—	180	ns
r/w Rise Delay Time	t_{d7}	—	—	180	ns
Data Stable Time	t_{d8}	—	—	450	ns
Data Hold Time	t_{d9}	—	—	200	ns

For more details, please refer to IC specification.

9.0 MECHANICAL DIAGRAM

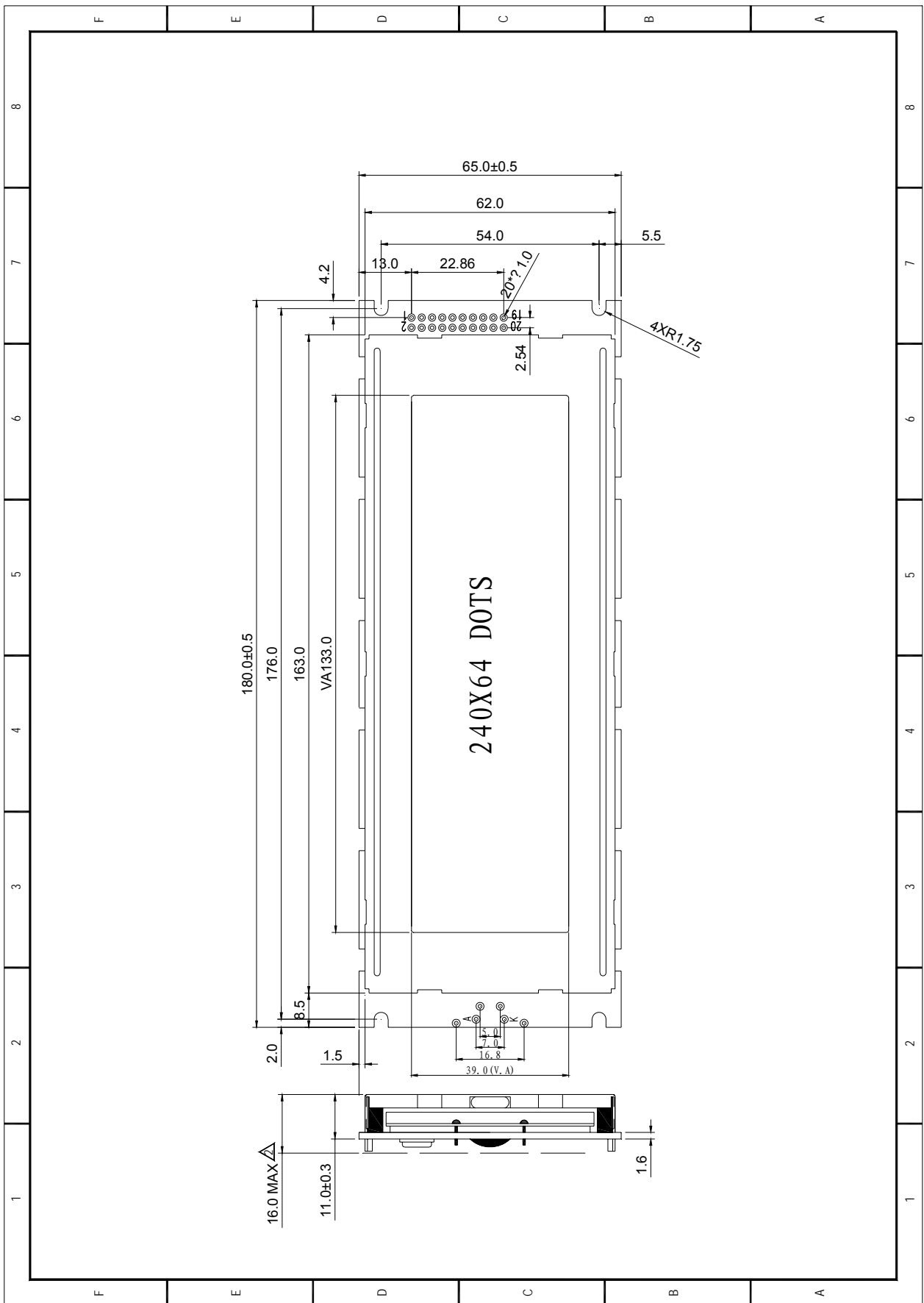

10.0 RELIABILITY TEST

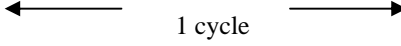
NO	Test Item	Description	Test Condition	Remark	
1	Environmental Test	High temperature storage	Applying the high storage temperature Under normal humidity for a long time Check normal performance	80 °C 96hrs	
2		Low temperature storage	Applying the low storage temperature Under normal humidity for a long time Check normal performance	-30°C 96hrs	
3		High temperature Operation	Apply the electric stress(Voltage and current) Under high temperature for a long time	70 °C 96hrs	Note1
4		Low temperature Operation	Apply the electric stress Under low temperature for a long time	-20°C 96hrs	Note1 Note2
5		High temperature/High Humidity Storage	Apply high temperature and high humidity storage for a long time	90% RH 40°C 96hrs	Note2
6		Temperature Cycle	Apply the low and high temperature cycle -30°C <-> 25°C <-> 80°C <-> 25°C 30min 10min 30min 10min  Check normal performance	-30°C/80°C 10 cycle	
7	Mechanical Test	Vibration test(Package state)	Applying vibration to product check normal performance	Freq:10~55~10Hz Amplitude:0.75mm 1cycle time:1min X.Y.Z every direction for 15 cycles	
8		Shock test(package state)	Applying shock to product check normal performance	Drop them through 70cm height to strike horizontal plane	
9	Other				

Remark

Note1:Normal operations condition (25°C±5°C).

Note2:Pay attention to keep dewdrops from the module during this test.



11.0 DISPLAY INSTRUCTION TABLE

INSTRUCTION	C/D	\overline{RD}	\overline{WR}	D7	D6	D5	D4	D3	D2	D1	D0	DESCRIPTION	
Status Read	1	0	1	S7	S6	S5	S4 Not used	S3	S2	S1	S0	S1~S5 0: In operation 1: Ready S6 0:No Error 1:Error S7 0:Display Off 1:Normal Display	
Register Set	1	1	0	0	0	1	0	0	0	0	1	Set Cursor Pointer Set Offset Register Set Address Pointer	
Control Word Set	1	1	0	0	1	0	0	0	0	0	0	Set Text Home Address Set Text Area Set Graphic Home Address Set graphic Area	
Mode Set	1	1	0	1	0	0	0	X X X X 0 1	0 0 0 1 X X	0 0 1 1 0 X X	0 1 1 0 X X X	OR mode EXOR mode AND mode Text Attribute mode Internal CG ROM mode External CG RAM mode	
Display Mode	1	1	0	1	0	0	1	0 X X 0 1 1	0 X X 1 0 1	0 1 1 X X X	0 1 1 X X X	Display Off Cursor on,blink off Cursor on,blink on Text on,graphic off Text off,graphic on Text on,graphic on	
Cursor Pattern Select	1	1	0	1	1	0	0	0	N 2	N 1	N 0	Cursor Set	
Data Auto Read /Write	1	1	0	1	0	1	1	0	0	0	0	Set Data Auto Write Set Data Auto Read Auto Reset	
Data Read Write	1	1	0	1	1	0	0	0	N 2	N 1	N 0	Data Read/Write And ADP Increment/Decrement It should executed after setting Address using Set Address Pointer command.	
Screen Peek	1	1	0	1	1	1	0	0	0	0	0	Screen Peek	
Screen Copy	1	1	0	1	1	1	0	1	0	0	0	Screen Copy	
Bit Set Reset	1	1	0	1	1	1	1	N 3	N 2	1	N 0	Bit Set	
Data Write	0	1	0	Write Data									Writes data DBO~DB7 from MPU to external display RAM.
Data Read	0	0	1	Read Data									Reads data DB0~DB7 from external display RAM to MPU.

x : invalid

For more information please check Controller Specification.

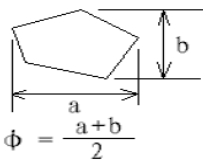
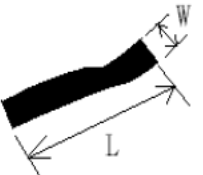
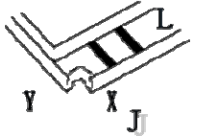
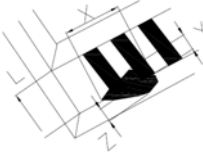
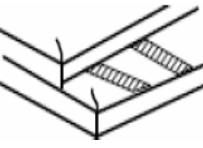
12.0 APPEARANCE CRITERIA

Item	Description	Picture	Specification			MA	MI	Inspection Method	
Dot defects (black/white dot)	Scratches black dot white dot on the polarizer dirty spot and bubble between the polarizer and glass in the display area.	 <p>$\phi = \frac{a+b}{2}$</p> <p>J:the distance between dot and dot.</p>	≤ 0.1	Ignored		●		Visual/contrast by Inspection standard film	
			$0.1 < \phi \leq 0.20$	2	J > 5				
			$0.20 < \phi \leq 0.25$	1	J > 10				
			$0.25 < \phi \leq 0.30$	0					
			$0.3 < \phi$	0					
black/white line defect (straight line or curve etc. Line type defects)	Fibres in active area, scratches and black line on the glass or polarizer.	 <p>J:the distance between dot and dot.</p>	$W \leq 0.01$	Ignored		●		Visual/contrast by Inspection standard film	
			$W \leq 0.02 \quad L \leq 5$	2	J > 5				
			$W \leq 0.03 \quad L \leq 4$	1	J > 10				
			$W \leq 0.04 \quad L \leq 3$	0	J > 10				
			$W \leq 0.05 \quad L \leq 2$	0					
Chip on corner	sidestep on the lower glass	 <p>Y:width of chip X:length of chip L:width of sidestep J:distance between electrode and the farthest edge.</p>	$Y \leq 1/2L, X \leq 1$	Ignored		●		Visual/contrast by Inspection standard film	
			$Y \leq 1/2L, X \leq 2$	2					
			$Y \leq 1/2L, X \leq 3$	1					
			$Y \leq 1/2L, X \leq 1/3J$	0	J ≤ 3				
			$Y \leq 1/2L, X \leq 2/3J$	0	J ≤ 3				
Crack		 <p>Y:width of crack X:length of crack L:width of sidestep T:depth of crack Z:thickness of single glass</p>	$Y \leq 1/5L, X \leq 5, Z \leq 1/2T$	Ignored		●		Visual/contrast by Inspection standard film	
			$Y \leq 1/4L, X \leq 5, Z \leq 1/2T$	2					
			$Y \leq 1/3L, X \leq 5, Z \leq 1/2T$	1					
			$Y \leq 1/3L, X \leq 10, Z \leq 1/2T$	0					
			$Y \leq 1/3L, X \leq 15, Z \leq 1/2T$	0					
Crack			Cracks in any area	rejected		●		Visual	
Polarizer			≤ 0.8	Accepted		●		Visual/	

AGM2464BD-FLW-GBW(AZ DISPLAYS) CHARACTER MODULE VER1.0

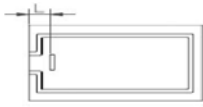
		be applicable for up/bottom polarizer	0.8<L≤1.0	Rejected			contrast by Inspection standard film
			1.0<L≤1.5	Rejected			
			1.5<L≤2.0	Rejected			
			Any seeable polarizer slanting or excursion in active area will be rejected. The polarizer edge should be even and be line. Any indentation within 1/3 of silkscreen line will be rejected. Wrong direction, missing or extra, incorrect sticking for polarizer and dirty surface(grease) on polarizer will be rejected. seeable black silkscreen line from the arond can be accepted. Refer to the drawing size requirement.				
End seal		 <p>L:The distance from the block to edge of glass.</p>	UV glue of seal on the glass surface	Rejected	●		Visual/contrast by Inspection standard film
			The UV glue of seal overflow into the active area.	Rejected			
			Direction of end seal is different from the drawing.	Rejected			
			Glue capacity of end seal < (1/3)*L	Rejected			
			the height and length of end seal is out of the drawing requirements.	Rejected			
Silkscreen line			silkscreen line overflow into the active area.	Rejected	●		Visual/contrast by Inspection standard film
			silkscreen line deviated in active area.	Rejected			
			bubble of silkscreen line ≥ 1/3 width of silkscreen line	Rejected			

AGM2464BD-FLW-GBW(AZ DISPLAYS) CHARACTER MODULE VER1.0

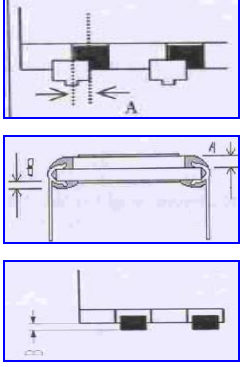
PIN			<p>Glue on PIN: there is glue on the PIN without pin clip will be rejected. PIN glue solidification: PIN glue doesn't solidify completely. The sunken or glue stain by touching will be rejected.</p> <p>PIN deflection: if deflection angle $> \pm 5^\circ$, rejected; contrarily, please refer to the drawing requirement. Without continuous glue on pins will be rejected.</p> <p>PIN glue stains on polarizer or inleakage polarizer and glass, rejected.</p> <p>PIN glue exceeds the up polarizer, rejected.</p> <p>Missing or extra, broken pin, rejected.</p> <p>PIN loosen: no permission for pin loose or drop. Clip</p> <p>PIN:pin center exceeds 1/3 ITO width, rejected. No pin glue, rejected. UV glue range: UV glue must be exceeded over 1~1.5 pin distance from both side. if not, rejected. PIN length and direction must be same with the drawing requirements.</p>		●	Visual/contrast by Inspection standard film	
Protective film			<p>LCD protective film can not stick on the polarizer and the product protective film raised $\leq 1/3$ length or width of polarizer from same direction of axis and its total length should be $\leq 15\text{mm}$. This defect can be accepted.</p>		●	Visual	
Rainbow			<p>rainbow is not in active area.</p> <p>Rainbow in active area.</p> <p>with obvious discoloration and uneven color.</p>	<p>Accepted</p> <p>Rejected</p> <p>Rejected</p>		●	Visual/contrast by golden sample
background color			<p>There are obvious different background color from the same product lot.</p>	<p>Rejected</p>		●	Visual/contrast by golden sample

NOTE:

Inspection condition:

Viewing distance for cosmetic inspection is 30cm with bare eyes, and under an environment of 800 lux(20W*2---40W) light intensity, all directions for inspecting the sample should be within 45° against perpendicular

13.0 PRECAUTION FOR USING LCM

1. When design the product with this LCD Module, make sure the viewing angle matches to its purpose of usage.
2. As LCD panel is made of glass substrate, Dropping the LCD module or banging it against hard objects may cause cracking or fragmentation. Especially at corners and edges.
3. Although the polarizer of this LCD Module has the anti-glare coating, always be careful not to scratch its surface. Use of a plastic cover is recommended to protect the surface of polarizer.
4. If the LCD module is stored at below specified temperature, the LC material may freeze and be deteriorated. If it is stored at above specified temperature, the molecular orientation of the LC material may change to Liquid state and it may not revert to its original state. Excessive temperature and humidity could cause polarizer peel off or bubble. Therefore, the LCD module should always be stored within specified temperature range.
5. Saliva or water droplets must be wiped off immediately as those may leave stains or cause color changes if remained for a long time. Water vapor will cause corrosion of ITO electrodes.
6. If the surface of LCD panel needs to be cleaned, wipe it swiftly with cotton or other soft cloth. If it is not still clean enough, blow a breath on the surface and wipe again.
7. The module should be driven according to the specified ratings to avoid malfunction and permanent damage. Applying DC voltage cause a rapid deterioration of LC material. Make sure to apply alternating waveform by continuous application of the M signal. Especially the power ON/OFF sequence should be kept to avoid latch-up of driver LSIs and DC charge up to LCD panel.
8. Mechanical Considerations
 - a) LCM are assembled and adjusted with a high degree of precision. Avoid excessive shocks and do not make any alterations or modifications. The following should be noted.
 - b) Do not tamper in any way with the tabs on the metal frame.
 - c) Do not modify the PCB by drilling extra holes, changing its outline, moving its components or modifying its pattern.
 - d) Do not touch the elastomer connector; especially insert a backlight panel (for example, EL).
 - e) When mounting a LCM makes sure that the PCB is not under any stress such as bending or twisting. Elastomer contacts are very delicate and missing pixels could result from slight dislocation of any of the elements.
 - f) Avoid pressing on the metal bezel, otherwise the elastomer connector could be deformed and lose contact, resulting in missing pixels.
9. Static Electricity
 - a) Operator

Wear the electrostatics shielded clothes because human body may be statically charged if not wear shielded clothes. Never touch any of the conductive parts such as the LSI pads; the copper leads on the PCB and the interface terminals with any parts of the human body.

b) Equipment

There is a possibility that the static electricity is charged to the equipment, which has a function of peeling or friction action (ex: conveyer, soldering iron, working table). Earth the equipment through proper resistance (electrostatic earth: 1×10^8 ohm).

Only properly grounded soldering irons should be used.

If an electric screwdriver is used, it should be well grounded and shielded from commutator sparks.

The normal static prevention measures should be observed for work clothes and working benches; for the latter conductive (rubber) mat is recommended.

c) Floor

Floor is the important part to drain static electricity, which is generated by operators or equipment.

There is a possibility that charged static electricity is not properly drained in case of insulating floor. Set the electrostatic earth (electrostatic earth: 1×10^8 ohm).

d) Humidity

Proper humidity helps in reducing the chance of generating electrostatic charges. Humidity should be kept over 50%RH.

e) Transportation/storage

The storage materials also need to be anti-static treated because there is a possibility that the human body or storage materials such as containers may be statically charged by friction or peeling.

The modules should be kept in antistatic bags or other containers resistant to static for storage.

f) Soldering

Solder only to the I/O terminals. Use only soldering irons with proper grounding and no leakage.

Soldering temperature : $280^{\circ}\text{C} \pm 10^{\circ}\text{C}$

Soldering time: 3 to 4 sec.

Use eutectic solder with resin flux fill.

If flux is used, the LCD surface should be covered to avoid flux spatters. Flux residue should be removed afterwards.

g) Others

The laminator (protective film) is attached on the surface of LCD panel to prevent it from scratches or stains. It should be peeled off slowly using static eliminator.

Static eliminator should also be installed to the workbench to prevent LCD module from static charge.

10. Operation

- a) Driving voltage should be kept within specified range; excess voltage shortens display life.
 - b) Response time increases with decrease in temperature.
 - c) Display may turn black or dark blue at temperatures above its operational range; this is (however not pressing on the viewing area) may cause the segments to appear "fractured".
 - d) Mechanical disturbance during operation (such as pressing on the viewing area) may cause the segments to appear "fractured".
11. If any fluid leaks out of a damaged glass cell, wash off any human part that comes into contact with soap and water. The toxicity is extremely low but caution should be exercised at all the time.
 12. Disassembling the LCD module can cause permanent damage and it should be strictly avoided.
 13. LCD retains the display pattern when it is applied for long time (Image retention). To prevent image retention, do not apply the fixed pattern for a long time. Image retention is not a deterioration of LCD. It will be removed after display pattern is changed.
 14. Do not use any materials, which emit gas from epoxy resin (hardener for amine) and silicone adhesive agent (dealcohol or deoxym) to prevent discoloration of polarizer due to gas.
 15. Avoid the exposure of the module to the direct sunlight or strong ultraviolet light for a long time.